

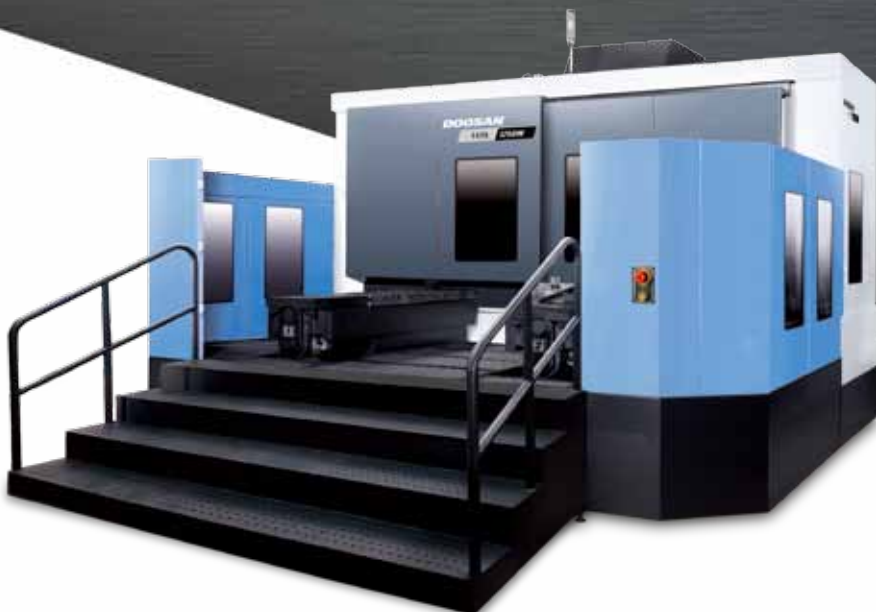

Optimal Solutions for the Future

HM 1000/1250/1250W

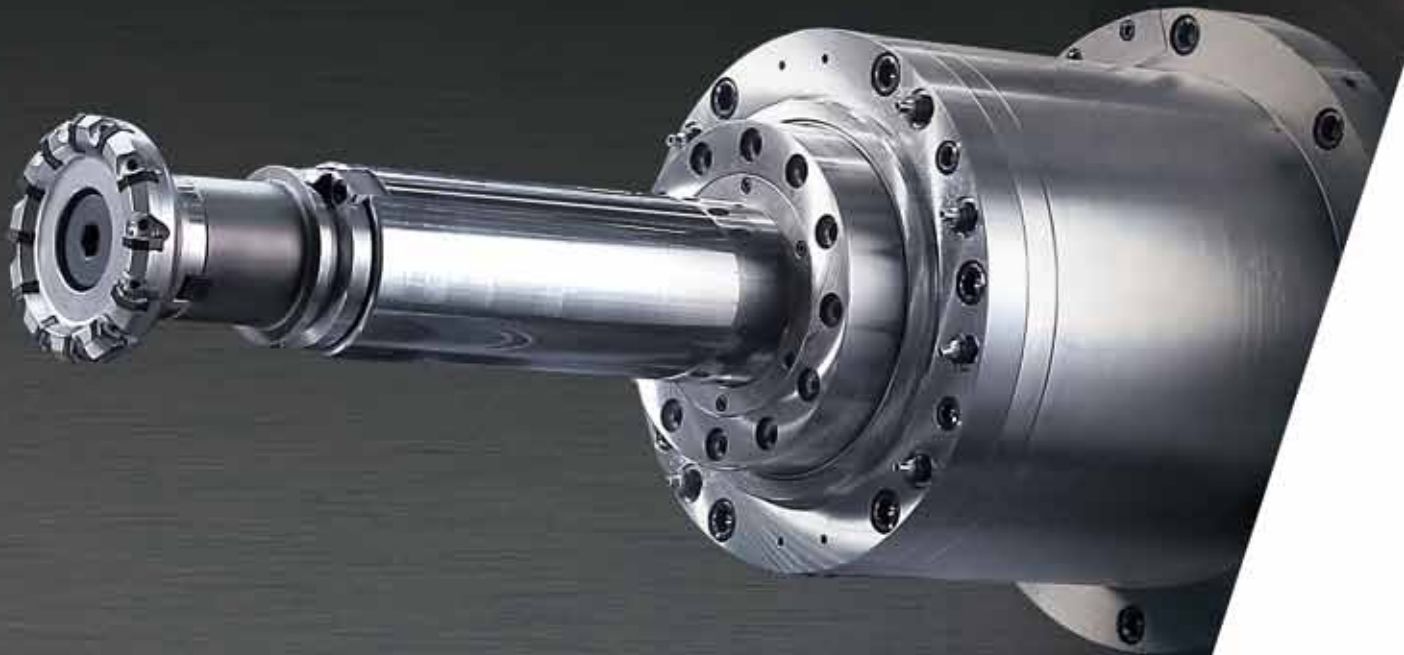

**Large Horizontal
Machining Center**

HM 1000

HM 1250

HM 1250W

ver. EN 150923 SU

Basic Information

Basic Structure
Cutting
Performance

Detailed Information

Options
Applications
Capacity Diagram
Specifications

Customer Support Service



HM 1000/1250/1250W

A twin pallet horizontal machining centre designed for processing large workpieces. A wide variety of machining applications can be carried out with the 1000/1250mm pallet size and optional W axis capability. The heavy duty box guideways, high torque gearbox spindle and minimum non-cutting time will provide users with a high level of productivity and added value.

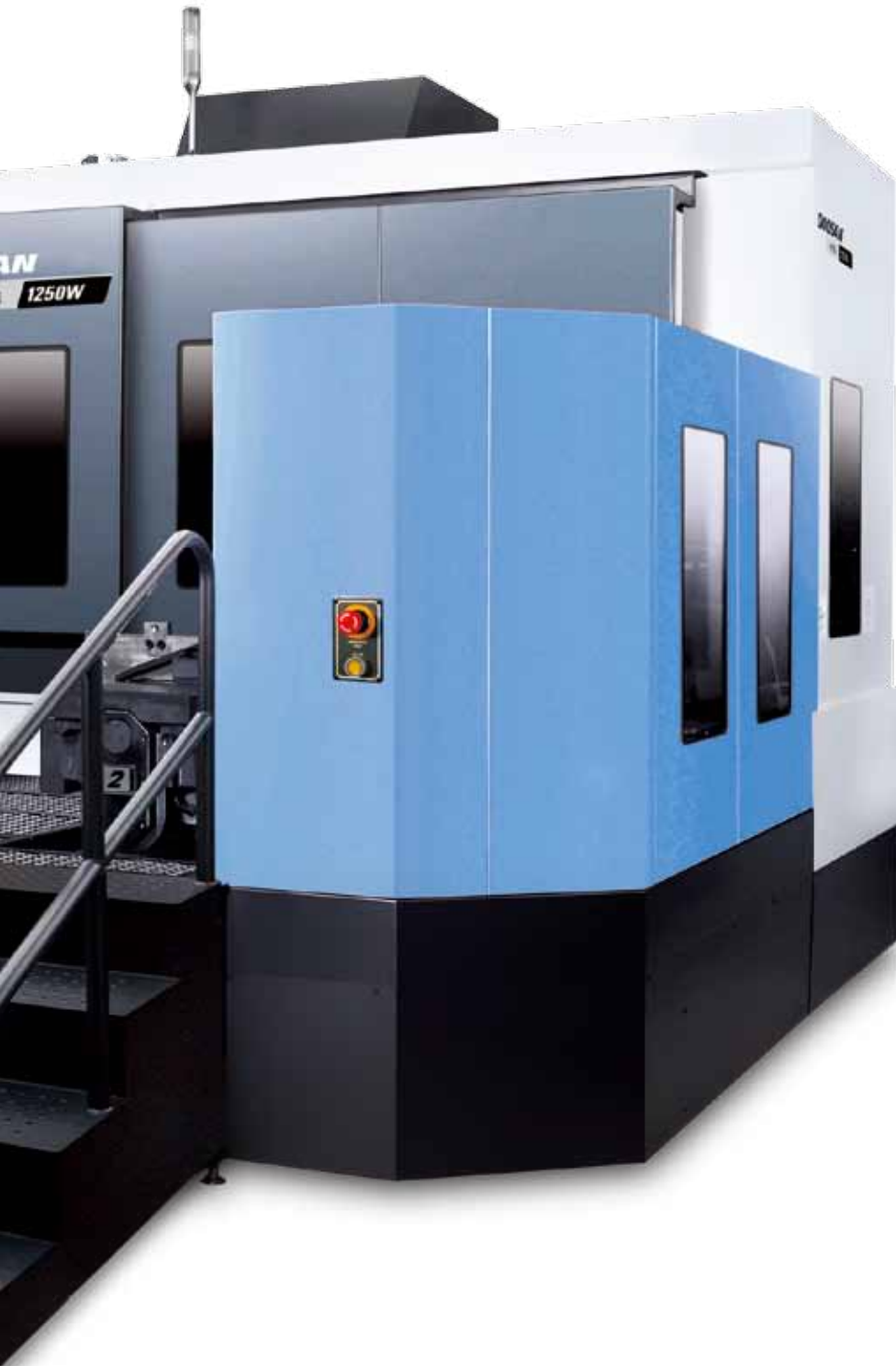

Contents

02 Product Overview

Basic Information

04 Basic Structure

06 Cutting Performance

Detailed Information

07 Standard / Optional Specifications

10 Applications

12 Capacity Diagram

15 Machine / NC Unit Specifications

18 Customer Support Service

Sample work



Improved Productivity with High Performance Specifications

High torque gearbox spindle, box-type guideways, and high rigidity cast structure achieves high productivity.

General type and optional W axis applications

A wide variety of large workpieces can be handled due to the machine's large capacity and optional W axis for long boring applications.

Ready for Automation with Standard Pallet Change System

The shuttle-type pallet changer satisfies the needs for long-term operation and automation.



Basic Structure

High rigidity bed supports high accuracy.

Large Horizontal Machining Center

Designed for for large workpieces requiring heavy duty cutting performance, the HM1000/1250/1250W offer the solution for various requirements.

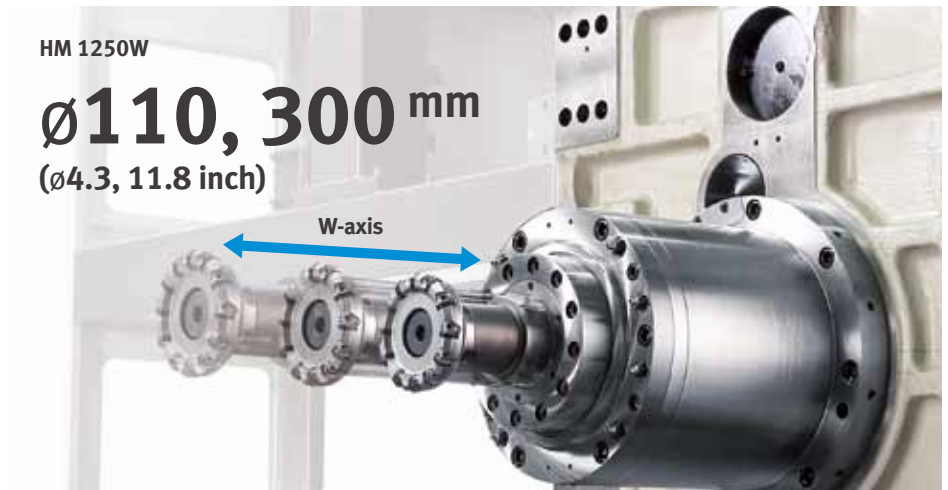

Axis system

Rigidity has been enhanced with box guideways.

Stable High-rigidity Axis Structure

All the linear axes are driven by high precision preloaded ballscrews to minimise thermal error. They are coupled directly to the absolute-type servo motor to optimise accuracy.

Axis system	Unit	HM 1000	HM 1250	HM 1250W
X-axis	mm (inch)	2100 (82.7)		
Y-axis	mm (inch)	1250 (49.2)	1500 (59.1)	1400 (55.1)
Z-axis	mm (inch)	1250 (49.2)	1500 (59.1)	1400 (55.1)
W-axis	mm (inch)	-	-	300
Rapid traverse rate (X / Y / Z / W)	m/min (ipm)	24 / 24 / 24 (944.9)	24 / 24 / 24 (944.9)	24 / 24 / 24 / 6 (944.9 / 236.2)

* The HM1250W Y-axis is applied with roller LM guideway.

Spindle

Gearbox driven spindle realizes high productivity.

Gearbox Spindle

High torque spindle, dual contact tool system, and spindle cooling system adopted as standard realize high stability and reliability.



Item	Unit	HM 1000 / 1250	HM 1250W
Max. spindle speed	r/min	6000 {6000, 8000}	3000
Spindle motor power (30min. / Cont.)	kW (Hp)	26 / 22 {37 / 30, 26 / 22} (34.9 / 29.5 {49.6 / 40.2, 34.9 / 29.5})	45 / 37 (60.3 / 49.6)
Max. spindle torque	N-m (ft-lb)	1989.4 {3687 / 1410} (1468.2 {2721.0 / 1040.6})	1910 (1409.6)

Spindle Cooling

Adopted as a standard feature, the oil cooler system minimizes thermal error over an extended time of operation the oil cooler system minimises thermal error over an extended period of operation.

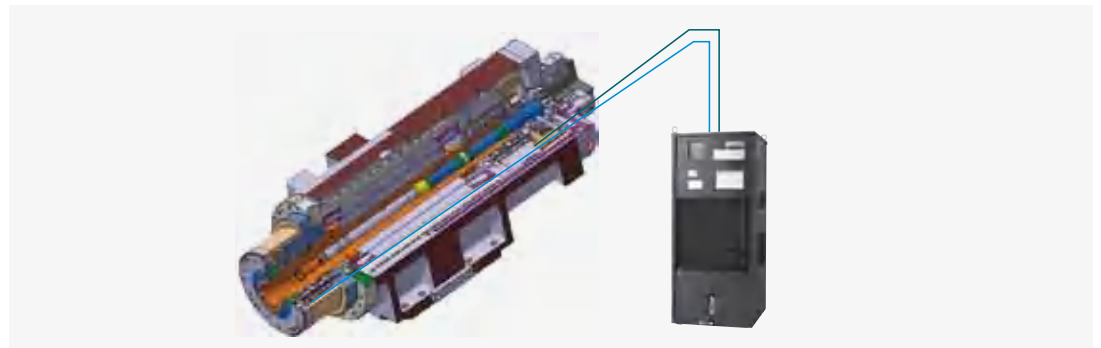

Magazine

Reliability is further improved with the adoption of servo motors and the tool storage capacity can be extended up to 196 tools.

Magazine

High durability and reliability are achieved by servo motors. Correct tool selection is guaranteed by fixed address system.



Tool change time (Tool-To-Tool)

10 sec

HM 1250W : 12 sec

Tool storage capacity

60 sec

option : 90 / 120 / 196



Item	Unit	HM 1000	HM 1250	HM 1250W
Tool storage capacity	ea	60 {90 / 120 / 196}		
Tool-to-Tool	sec	10		12
Max. tool diameter (Neighboring pot empty)	mm (inch)	130 (300) (5.1(11.8))		
Max. tool length	mm (inch)	650 (25.6)	650 {800} (25.6 {31.5})	700 (27.6)
Max. tool weight	kg (lb)	30 (66.1)		

Table

The table capacity is suitable for large workpieces.

Table

The shuttle-type, automatic pallet changer as standard specification improves productivity.

HM 1000 / 1250

3000 kg
(6613.8 lb)

5000kg option
(11023.0 lb)

HM 1250W

5000 kg
(11023.0 lb)

Item	Unit	HM 1000	HM 1250	HM 1250W
Pallet size	mm (inch)	1000 x 1000 {1250 x 1000} (39.4 x 39.4 {49.2 x 39.4})	1250 x 1250 {1250 x 1000} (49.2 x 49.2 {49.2 x 39.4})	
Max. work size	mm (inch)	2000 x 1475 (78.7 x 58.1)	2000 {2300} x 1725 (18.7 {90.6} x 67.9)	
Loading capacity	kg (lb)	3000 {5000} (6613.8 {11023.0})		5000 (11023.0)

Machining Performance

HM 1250W

Face mill (material : SM45C / W-axis : 300 mm (11.8 inch))						
Tool mm (inch)	Spindle speed r/min	Feed rate mm/min (ipm)	Cutting width mm (inch)	Cutting depth mm (inch)	Chip removal rate cm ³ /min (inch)	
D125 (D4.9)	360	300 (11.8)	80 (3.1)	1.7 (0.1)	1176 (71.8)	
Face mill (material : SM45C / W-axis : 0 mm (0 inch))						
Tool mm (inch)	Spindle speed r/min	Feed rate mm/min (ipm)	Cutting width mm (inch)	Cutting depth mm (inch)	Chip removal rate cm ³ /min (inch)	
D125 (D4.9)	300	1680 (66.1)	100 (3.9)	7 (0.3)	1176 (71.8)	
	300	1400 (55.1)	100 (3.9)	8 (0.3)	1120 (68.3)	
	300	1300 (51.2)	100 (3.9)	9 (0.4)	1170 (71.4)	
U-drill						
Tool mm (inch)	Spindle speed r/min	Feed rate mm/min (ipm)	Cutting depth mm (inch)			
D85 (D3.3)	560	165 (6.5)	50 (2.0)			
D120 (4.7)	380	77 (3.0)	50 (2.0)			
Tap						
Tool mm (inch)	Spindle speed r/min	Feed rate mm/min (ipm)	Cutting depth mm (inch)			
M48 x 5 (M1.9 x 0.2)	100	500 (19.7)	45 (1.8)			

* The results, indicated in this catalogue are provides as example. They may not be obtained due to differences in cutting conditions and environmental conditions during measurement.



Standard / Optional Specifications

Diverse optional features are available for customer-specific requirements.

● Standard ○ Optional X N/A

NO.	Description	Features	HM 1000	HM 1250	HM 1250W
1	PALLET TYPE	0.001 DEGREE	○	○	○
2		1 DEGREE	●	●	●
3	NO. OF PALLETS	2 EA	●	●	●
4		2 EA + 1 SPARE PALLET	○	○	○
5		2 EA + 2 SPARE PALLETS	○	○	○
6		2 EA + 3 SPARE PALLETS	○	○	○
7		2 EA + 4 SPARE PALLETS	○	○	○
8		6 PALLETS MAGAZINE STATION - PMG	○	○	○
9	PALLET CHECK SYSTEM	AIR LIMIT SENSING	○	○	○
10	PALLET SIZE	1000 X 1000 MM	●	○	○
11		1250 X 1000 MM	○	○	○
12		1250 X 1250 MM	○	●	●
13	REFERENCE OF WORKPIECE SETTING	CENTER BUSH	○	○	○
14	TOOL STORAGE CAPACITY	120 EA	○	○	○
15		60 EA	●	●	●
16		90 EA	○	○	○
17	AUTO TOOL MEASURING DEVICE	ENCODER NEEDLE TYPE_BK MIKRO	○	○	○
18		OMRON LIMIT SWITCH TYPE	○	○	○
19		RMI-Q_ONLY_RENISHAW	○	○	○
20		TS27R_RENISHAW	○	○	○
21	AIR	AIR BLOWER	○	○	X
22		AIR GUN	○	○	○
23	OIL SKIMMER	BELT TYPE	○	○	○
24	COOLANT	COOLANT GUN	○	○	○
25		SHOWER COOLANT	○	○	○
26	THROUGH SPINDLE COOLANT	1.5 kW_2.0 MPA	○	○	○
27		1.5 kW_2.0 MPA_CYCLON FILTER	○	○	○
28		1.5 kW_3.0 MPA_COOLJET BAG FIL	○	○	○
29		3.7 kW_7.0 MPA_BAG FILTER	○	○	○
30		3.7 kW_7.0MPA_PAPER ROLL FILTER	○	○	○
31		4.0 kW_2.0 MPA	○	○	○
32		3.0 kW_3.0 MPA_CYCLON FILTER	○	○	○
33		5.5 kW_7.0 MPA_DUAL BAG FILTER	○	○	○
34	7.5 kW_7.0 MPA_CYCLON FILTER	○	○	○	
35	AUTO WORKPIECE MEASURING DEVICE	OMP60_RENISHAW	○	○	○
36		RMP60_RENISHAW	○	○	○
37	CALIBRATION BLOCK	CALIBRATION BLOCK	○	○	○
38	CHIP CONVEYOR	FORKLIFT_380L	○	○	○
39		ROTATION_380L	○	○	○
40		HINGED BELT_LEFT SIDE	○	○	○
41		MAGNETIC SCRAPER_LEFT SIDE	○	○	○
42	LINEAR SCALE (X/Y/Z AXIS)	ABSOLUTE PULSE CODER	○	○	○
43	MIST COLLECTOR	2.2 KW_NONE WATER SOLUBLE	○	○	○
44		2.2 KW_WATER SOLUBLE	○	○	○
45	SAFETY SENSOR FOR OPERATOR	ARRAY SENSOR	○	○	○
46	TEST BAR	TEST BAR GAUGE	○	○	○
47	WORK LOCATING CONFIRMATION	AIR LIMIT SENSING_2 PORT	○	○	○
48	AIR CONDITIONER	AIR CONDITIONER	○	○	○
49	AUTOMATIC POWER OFF	AUTOMATIC POWER OFF	○	○	○
50	AUTOMATIC POWER ON	AUTOMATIC POWER ON	○	○	○
51	ELECTRIC CABINET LIGHT	ELECTRIC CABINET LIGHT	○	○	○
52	FASTEMS FMS INTERFACE	FASTEMS FMS INTERFACE	○	○	○
53	MPG	3 MPG_PORTABLE TYPE	○	○	○

* For further details on the options, please contact Doosan.

Diverse Options

Chip Conveyor



Environment Friendly Devices



Cutting Oil Cooling System

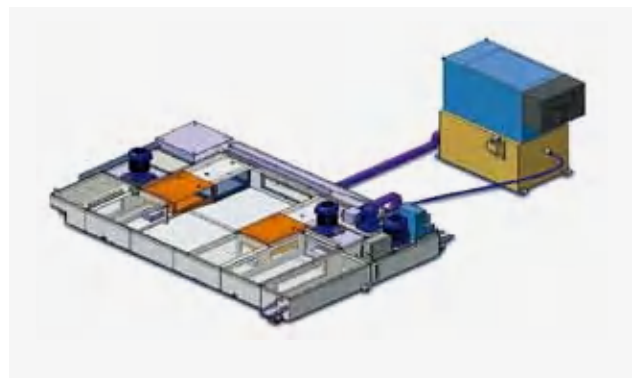

Linear Scale Feedback System



Chip Disposal System



Measurement Systems





DOOSAN
Multi pallet system

PMG (Pallet Magazine)

The PMG system is composed of a rotating pallet pool storage unit and a feed mechanism to transfer the pallet to and from the machine working area. In addition, a pallet can be transferred to a separate setup station where the operator has allround access for loading the workpiece.

Features

- Conventional multi pallet changer round type
- Available large volume workpiece
- Driven by hydraulic unit
- Stable pallet changing unit
- Pallet scheduling operation (1-Path, PMC control)

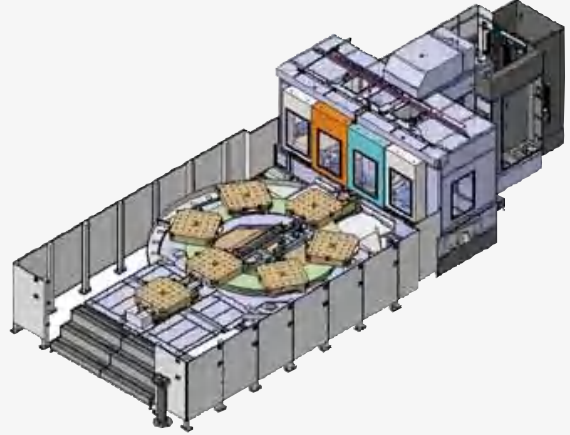

External Dimensions

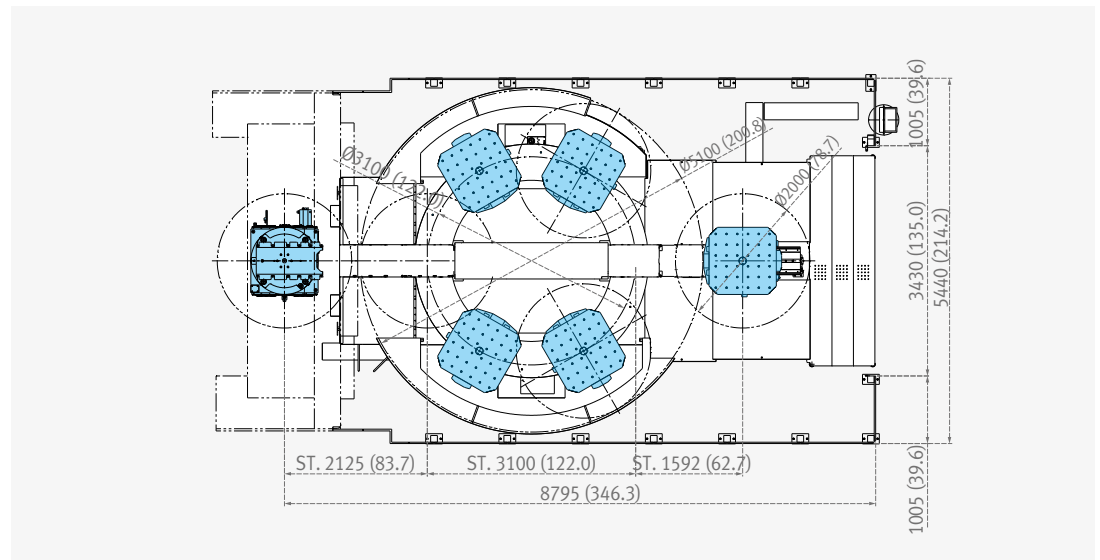

Machine Specifications

Available Model		HM 1000	HM 1250
Pallet Dimension	mm (inch)	1000 x 1000 (39.4 x 39.4)	1250 x 1000 (49.2 x 39.4)
Workpiece Diameter	mm (inch)	2000 (78.7)	2000 (78.7)
Workpiece Height	mm (inch)	1475 (58.1)	1725 (67.9)
Workpiece Weight	kg (lb)	3000 (6613.8)	3000 (6613.8)
Magazine type		Round type	
Operation		Pallet scheduling operation (1-Path, PMC control)	
Pallet Drive Device		HYDRAULIC MOTOR & CHAIN	
Hydraulic Power Unit	kW (Hp)	7.5 (10.1)	



User Convenience

User convenience has been significantly enhanced with a new operation panel.

Simple and Convenient Operation Panel

The operator's panel has been redesigned and integrated for better usability. Additional, customized function switches (option) can be provided to maximize the operator's convenience.



Clamping fixture lock/unlock button, counter, timer and other special optional buttons can be provided.

The buttons are separated by partitions in order to prevent erroneous operation of the buttons.

Portable MPG

The portable MPG allows the user to set up workpieces more easily.



PCMCIA Card

The PCMCIA card enables uploading and downloading of the NC program, NC parameters, tool information, and ladder programs, and also supports DNC operation.

USB Port

Upload/download of NC software programs, NC parameters, tool information and ladder program using a USB drive is allowed, but DNC operation is not supported.



EOP Function

Doosan's Easy Operation Package (EOP) supports the user with tool, help desk, operation, and pallet magazine functions among others.

Easy Operation Package

Doosan's EOP supports the user with tool, help desk, operation, and pallet magazine functions among others to maximize operational efficiency and user convenience.

Tool Support Functions



Tool management I

- Tool magazine control
- Tool state display
- Fastems Tool Add/Remove Function **option**

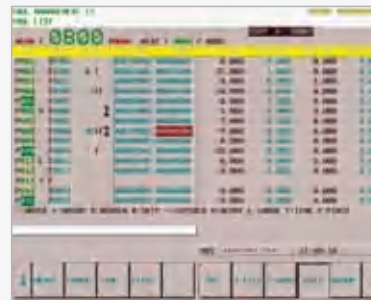

Tool management II **option**

- Tool magazine control
- Tool life management
- Tool life prediction
- Tool state control
- Balluff Tool ID function



Tool load monitor **option**

- Detection of tool damage
- Detection of abnormalities during operation
- Detection of no-load air cutting



ATC / APC panel

- ATC manual
- APC manual

Operation Support Functions



Operation rate

- Measure various machine operating rate
- Support 3 shift operation
- calculate and save 30 days operating rate
- Show data for a specific period



PMC switch

- Operation panel function (option)
- Substitutes toggle switches
- NC option software

Spindle Power – Torque Diagram

Basic Information

Basic Structure
Cutting
Performance

Detailed Information

Options
Applications
Capacity Diagram
Specifications

Customer Support Service

HM 1000 / 1250

Max. spindle speed : 6000 r/min
Spindle motor power : 26 / 22 kW (34.9 / 29.5 Hp)

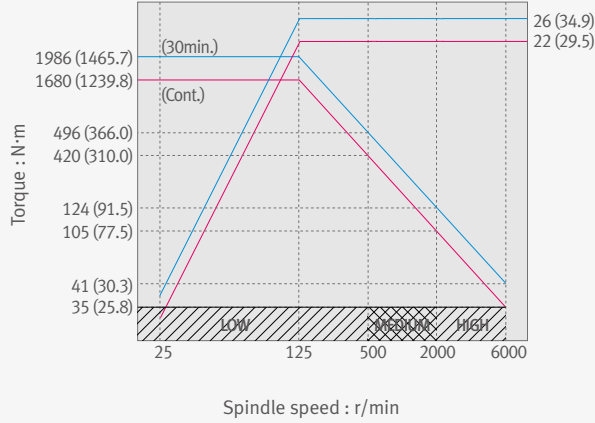

Max. spindle speed : 6000 r/min **option**
Spindle motor power : 30 / 37 kW (49.6 / 40.2 Hp)

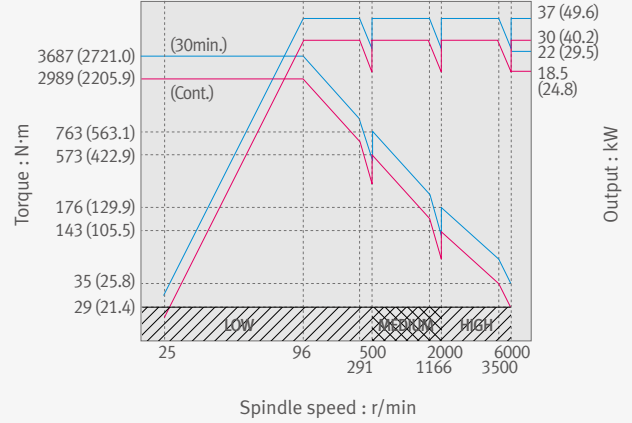

Max. spindle speed : 8000 r/min **option**
Spindle motor power : 26 / 22 kW (34.9 / 29.5 Hp)

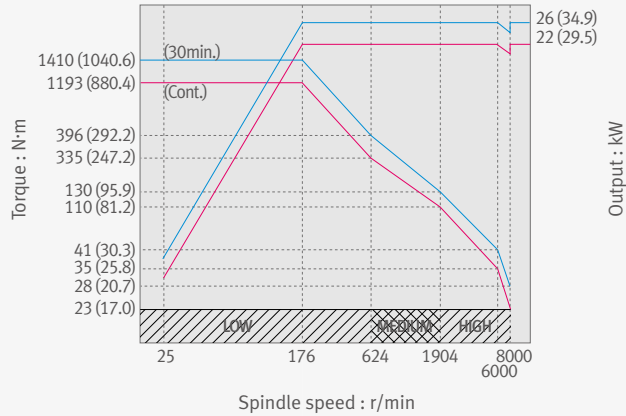

HM 1250W

Max. spindle speed : 3000 r/min
Spindle motor power : 45 / 37 kW (60.3 / 49.6 Hp)
(30min. / Cont.)

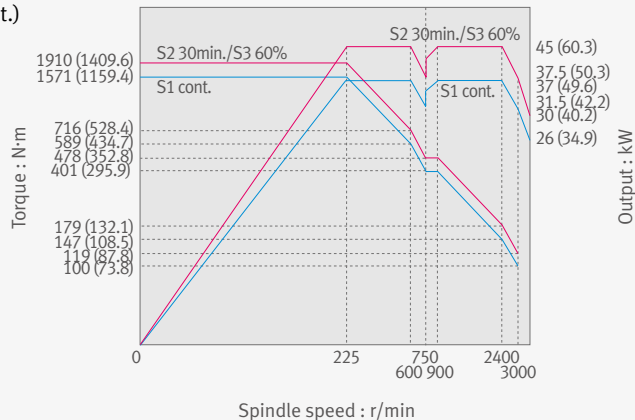

External Dimensions

HM 1000 / 1250 / 1250W

Unit : mm (inch)

Top View

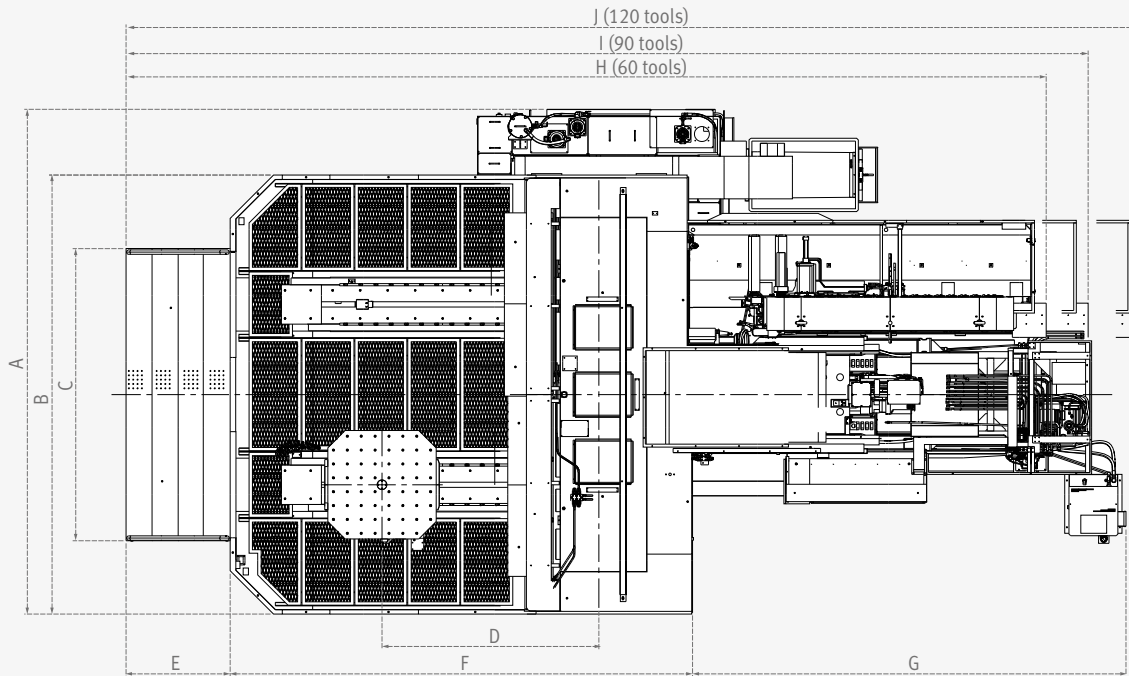

Model	A	B	C	D	E	F	G	H	I	J
HM 1000	5822 (229.2)	5064 (199.4)	3370 (132.7)	2100 (82.7)	1162 (45.7)	4780 (188.2)	3715 (146.3)	9928 (390.9)	10411 (409.9)	11035 (434.4)
HM 1250	5822 (229.2)	5064 (199.4)	3370 (132.7)	2500 (98.4)	1200 (47.2)	5330 (209.8)	4000 (157.5)	10530 (414.6)	11000 (433.1)	11623 (457.6)
HM 1250W	5822 (229.2)	5064 (199.4)	3370 (132.7)	2500 (98.4)	1200 (47.2)	5330 (209.8)	4996 (196.7)	10606 (417.6)	11089 (436.6)	11713 (461.1)

Front View

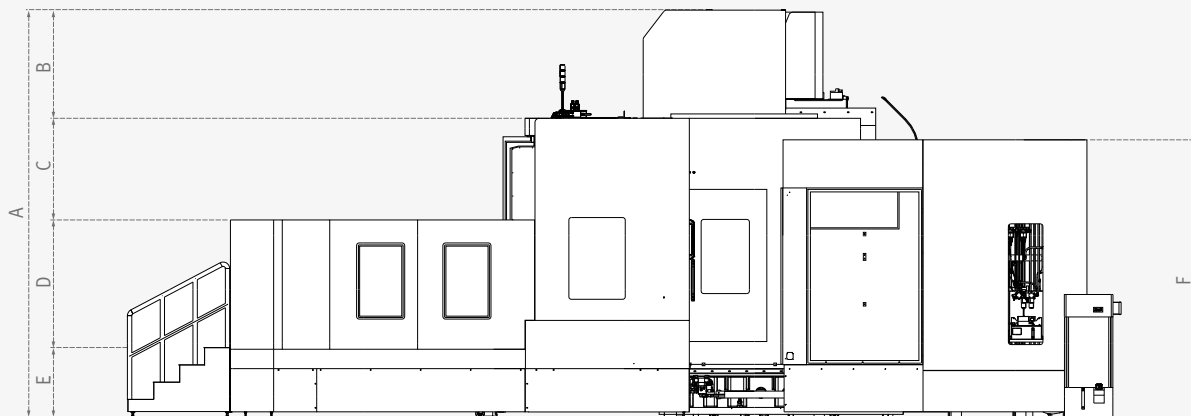

Model	A	B	C	D	E	F
HM 1000	3885 (153.0)	660 (26.0)	929 (36.6)	1493 (58.8)	803 (31.6)	3225 (127.0)
HM 1250	4130 (162.6)	660 (26.0)	1179 (46.4)	1493 (58.8)	803 (31.6)	3225 (127.0)
HM 1250W	4581 (180.4)	1106 (43.5)	1179 (46.4)	1481 (58.3)	815 (32.1)	3225 (127.0)

External Dimensions

Basic Information

Basic Structure
Cutting
Performance

Detailed Information

Options
Applications
Capacity Diagram
Specifications

Customer Support Service

Table dimensions

Unit : mm (inch)

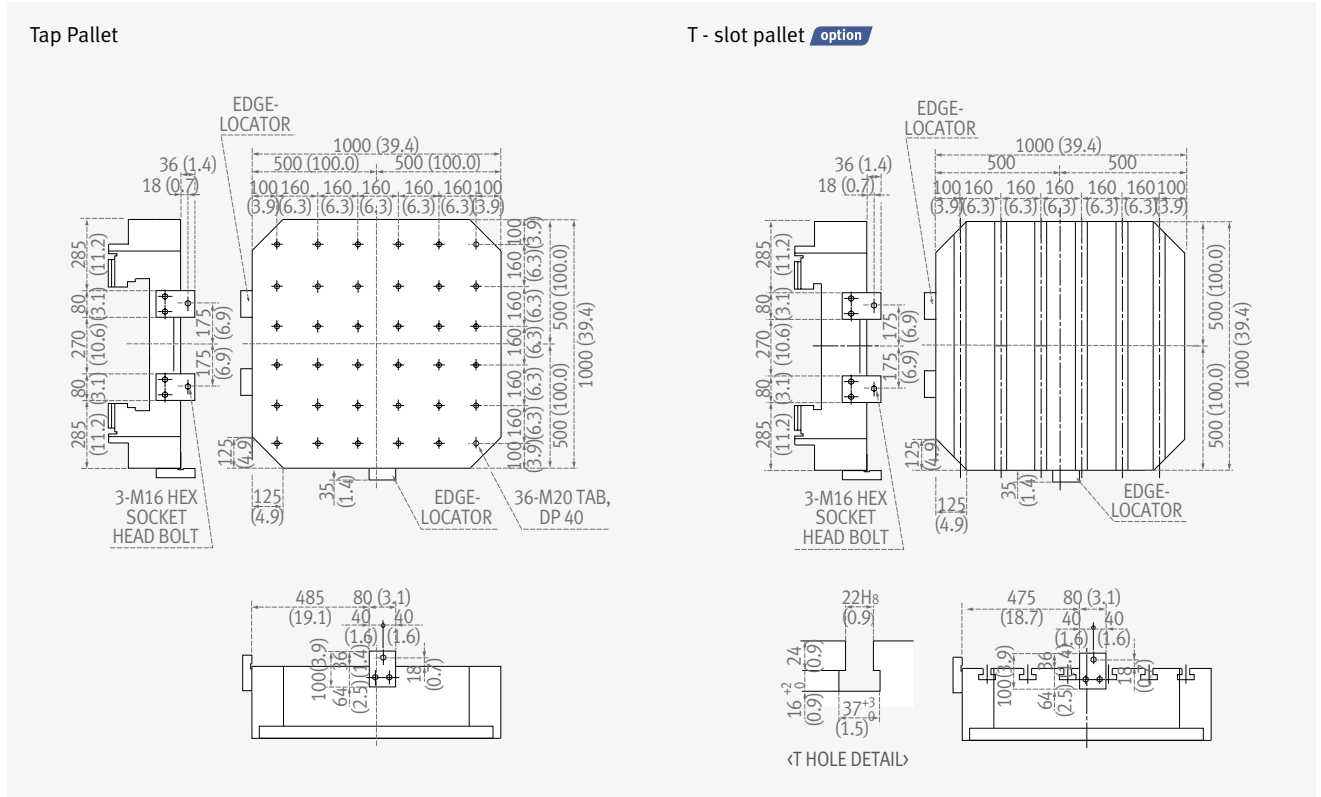

Tool Shank

Unit: mm (inch)

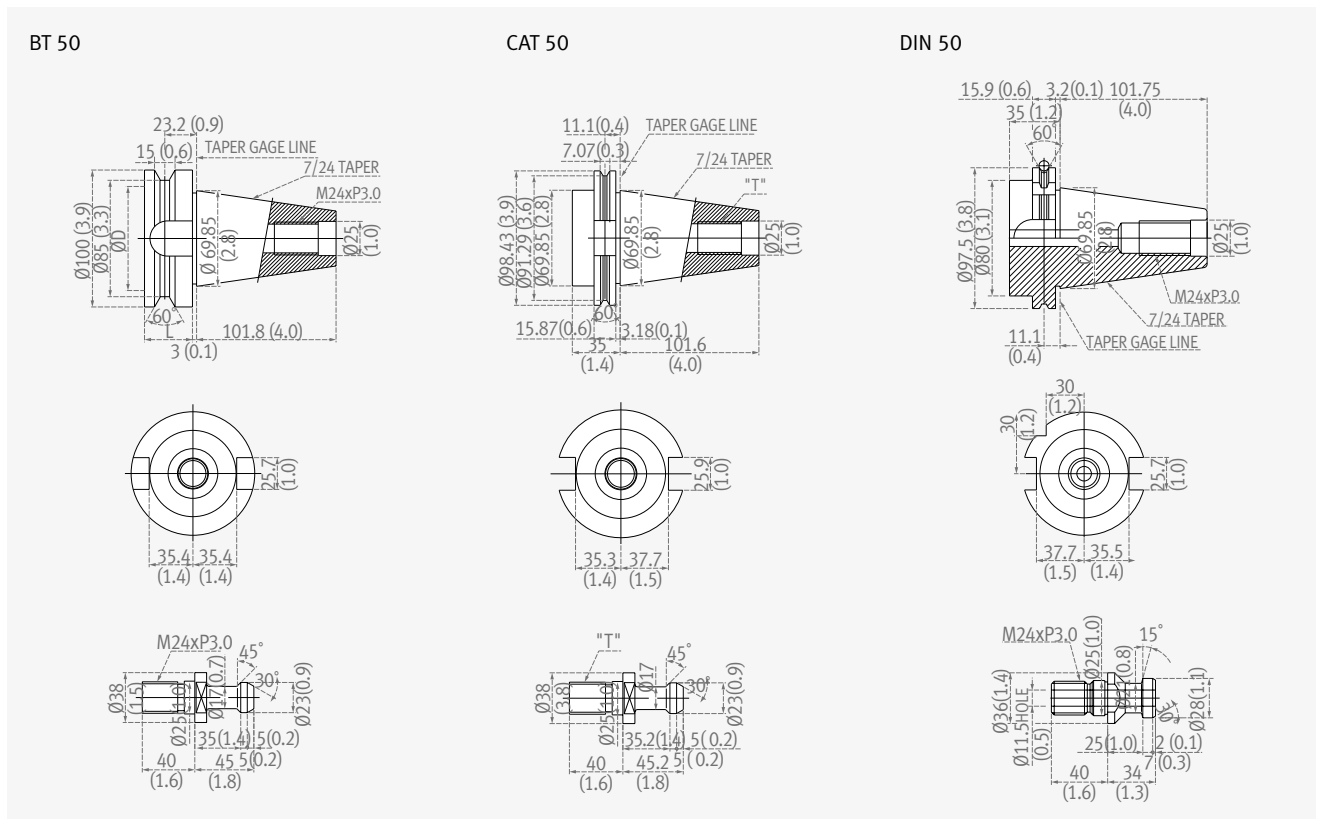

Machine Specifications



Description		Unit	HM 1000	HM 1250	HM 1250W
Travels	X-axis	mm (inch)	2100 (82.7)		
	Y-axis	mm (inch)	1250 (49.2)	1500 (59.1)	1400 (55.1)
	Z-axis	mm (inch)	1250 (49.2)	1500 (59.1)	1400 (55.1)
	W-axis	mm (inch)	-	-	300 (11.8)
Table	Distance from table top to spindle nose	mm (inch)	75 ~ 1325 (3.0 ~ 52.2)	50 ~ 1550 (2.0 ~ 61.0)	50 ~ 1450 (2.0 ~ 57.1)
	Table size	mm (inch)	1000 x 1000 {1250 x 1000}* (39.4 x 39.4 {49.2 x 39.4}*)	1250 x 1250 {1250 x 1000}* (49.2 x 49.2 {49.2 x 39.4}*)	
	Loading capacity	kg (lb)	3000 {5000}* (6613.8 {11023.0}*)		5000 (11023.0)
	Table type	-	36-M20 x P2.5 {44-M20 x P2.5}*	60-M2 x P2.5 {44-M20 x P2.5 / 36-M20 x P2.5}*	
	Max. workpiece size (Ø x H)	-	1* {0.001"}*		
Spindle	Max. spindle speed	r/min	6000 {6000 / 8000}*		3000
	Taper	-	ISO #50, 7/24		
	Max. spindle torque	N·m (ft·lb)	1989.4 {3687 / 1410}* (1468.2 {2721.0 / 1040.6}*)		1910 (1409.6)
	Spindle motor power	kW (Hp)	26 / 22 {37 / 30, 26 / 22}* (34.9 / 29.5 {49.6 / 40.2, 34.9 / 29.5}*)		45 / 37 (60.3 / 49.6)
Feedrate	Rapid traverse rate (X / Y / Z / W)	m/min (ipm)	24 / 24 / 24 (944.9 / 944.9 / 944.9)		24 / 24 / 24 / 6 (944.9 / 944.9 / 944.9 / 236.2)
	Cutting feedrate	mm/min (ipm)	12000 (472.4)		
ATC	Type of tool shank	-	BT / CAT / DIN 50		
	Tool storage capacity	ea	60 {90 / 120 / 196}*		
	Max. tool diameter (Neighboring pot empty)	mm (inch)	130 (300) (5.1(11.8))		
	Max. tool length	mm (inch)	650 (25.6)	650 {800}* (25.6 {31.5}*)	700 (27.6)
	Max. tool weight	kg (lb)	30 (66.1)		
	Method of tool selection	-	Fixed address		
	Tool change time (Tool-To-Tool)	sec	10		12
Machine Dimensions	Length x Width	mm (inch)	9657 x 5822 (380.2 / 229.2)	10530 x 5822 (414.6 / 229.2)	11526 x 5822 (453.8 / 229.2)
	Height	mm (inch)	3885 (153.0)	4130 (162.6)	4581 (180.4)
	Weight	kg (lb)	29000 (63933.1)	31000 (68342.3)	33000 (72751.5)
CNC	NC system	-	FANUC 31i		
Power source	Electric power	kVA	71 {82, 68.5}* – spindle type		90

* { } : Option

NC Unit Specifications

● Standard ○ Optional X N/A



Basic Information

Basic Structure
Cutting
Performance

Detailed Information

Options
Applications
Capacity Diagram
Specifications

Customer Support Service

No.	Item	Spec.	FANUC 31i	
1	Controlled axes	4 (X,Y,Z,B)	X, Y, Z, B	
2	Additional controlled axes	ADD 1 AXIS (5TH AXIS)	○	
3	Simultaneously controlled axes	Positioning(G00)/Linear interpolation(G01) : 3 axes Circular interpolation(G02, G03) : 2 axes	●	
4	Least command increment	0.001 mm / 0.0001"	●	
5	Least input increment	0.001 mm / 0.0001"	●	
6	Increment system C	IS-C	○	
7	Interpolation type pitch error compensation		●	
8	Position switch		○	
9	Inverse time feed		○	
10	Cylindrical interpolation	G07.1	○	
11	NURBS interpolation		○	
12	Bell-type acceleration/deceleration before look ahead interpolation	Included in AI contour control I or II (Oi-MF, 31/32i)	●	
13	Rigid tapping bell-shaped acceleration/deceleration	Rigid tapping is required.	○	
14	AXES CONTROL	Exponential interpolation	○	
15		Involute interpolation	○	
16		Smooth backlash compensation	●	
17		Automatic corner override	G62	○
18		Automatic corner deceleration	Included in AI contour control I or II (Oi-MF, 31/32i)	●
19		Cutting feedrate clamp		●
20		Rapid traverse bell-shaped acceleration/deceleration		●
21		Handle interruption		○
22		Manual handle retrace		○
23		Manual handle feed 2/3 unit		○
24		Nano smoothing		○
25		AICC II	200BLOCK	●
26	AICC II	400 BLOCK	○	
27	High-speed processing	600 BLOCK	○	
28	Look-ahead blocks expansion	1000 BLOCK	○	
29	Linear ACC/DEC before cutting feed interpolation		●	
30	SPINDLE & M-CODE FUNCTION	M-code function	M 3 digits	
31		Spindle orientation		
32		Retraction for rigid tapping		
33		Rigid tapping	G84, G74	
34	TOOL FUNCTION	Number of tool offsets	200-pairs	
35		Number of tool offsets	400-pairs	
36		Number of tool offsets	499 / 999 / 2000 -pairs	
37		Tool nose radius compensation	G40, G41, G42	
38		Tool length compensation	G43, G44, G49	
39		Tool life management		
40		Addition of tool pairs for tool life management		
41		Tool number command	T3 digits	
42		Tool offset memory C	Geometry / Wear and Length / Radius offset memory	
43		Tool length measurement		
44		Tool length offset		
45		Tool offset	G45 - G48	
46		Rotary table dynamic fixture offset		
47		Work setting error compensation		
48	PROGRAMMING & EDITING FUNCTION	Absolute / Incremental programming	G90 / G91	
49		Automatic Coordinate system setting		
50		Background editing		
51		Canned cycle	G73, G74, G76, G80 - G89, G99	
52		Circular interpolation by radius programming		
53		Custom macro		
54		Addition of custom macro common variables	#100 - #199, #500 - #999	

NC Unit Specifications

● Standard ○ Optional X N/A

FANUC

No.	Item	Spec.	FANUC 31i
55	Macro executor		●
56	Custom software	8MB	●
57	Custom software	12MB, 16MB	○
58	Decimal point input		●
59	Extended P-code variables 512Kbyte		●
60	Extended part program editing		●
61	Part program storage	256KB(640m)	●
62	Part program storage	512KB(1280m)	○
63	Part program storage	1MB(2560m)	○
64	Part program storage	2MB(5120m)	○
65	Part program storage	4MB(10240m)	○
66	Part program storage	8MB(20480m)	○
67	Inch/metric conversion	G20 / G21	●
68	Label skip		●
69	Maximum commandable value (□□□□□)	±99999.999mm (±9999.9999 inch)	●
70	Number of Registered programs	500 ea	●
71	Optional block skip	1 BLOCK	●
72	Optional block skip	9 BLOCK	○
73	Optional stop	M01	●
74	Program file name	32 characters	●
75	Playback function		○
76	Workpiece coordinate system	G52 - G59	●
77	Addition of workpiece coordinate system	G54.1 P1 - 48 (48 pairs)	●
78	Addition of workpiece coordinate system	G54.1 P1 - 300 (300 pairs)	○
79	Tilted working plane indexing command	G68.2	○
80	Embeded Ethernet		●
81	MDI / DISPLAY unit	10.4" Color LCD, Keyboard for data input, soft-keys	●
82	MDI / DISPLAY unit	15" Color LCD, Keyboard for data input, soft-keys	●
83	I/O interface	RS - 232C	○
84	USB memory interface	Only Data Read & Write	●
85	Stored stroke check 2		●
86	Multi language display		○
87	3rd / 4th reference return		●
88	Cs contouring control		●
89	Reader/Puncher interface (for 2ch)		○
90	Retraction for 3-dimensional rigid tapping		●
91	Extended Spindle orientation(Spindle Multi Orientation)		○
92	Chopping function	G81.1	●
93	High speed skip function		○
94	Polar coordinate command	G15 / G16	○
95	Polar coordinate interpolation	G12.1 / G13.1	○
96	Programmable mirror image	G50.1 / G51.1	○
97	Scaling	G50, G51	○
98	Single direction positioning	G60	○
99	Pattern data input		○
100	Jerk control	AI contour control II is required.	○
101	Fast Data server with1GB PCMCIA card		○
102	Fast Ethernet		○
103	3-dimensional coordinate conversion		○
104	3-dimensional tool compensation		○
105	3-dimensional manual feed		○
106	Tape format for FS15		○
107	Figure copying	G72.1, G72.2	○
108	Machining time stamp function		○
109	Machining quality level adjustment		○
110	EZ Guide I with 10.4" Color TFT	Doosan infracore Conversational Programming Solution -.When the EZ Guide i is used, the Dynamic graphic display cannot application	○
111	Dynamic graphic display (with 10.4" Color TFT LCD)	Machining profile drawing. -.When the EZ Guide i is used, the Dynamic graphic display cannot application	○

Responding to Customers Anytime, Anywhere

Basic Information

- Basic Structure
- Cutting
- Performance

Detailed Information

- Options
- Applications
- Capacity Diagram
- Specifications

Customer Support Service



Global Service Support Network

Corporations

5

Dealer Networks

128

Technical Centers

21

Factories

4

Technical Center: Sales Support, Service Support, Parts Support

Doosan Machine Tools' Global Network, Responding to Customer's Needs nearby, Anytime, Anywhere

Doosan machine tools provides a system-based professional support service before and after the machine tool sale by responding quickly and efficiently to customers' demands. By supplying spare parts, product training, field service and technical support, we can provide top class support to our customers around the world.

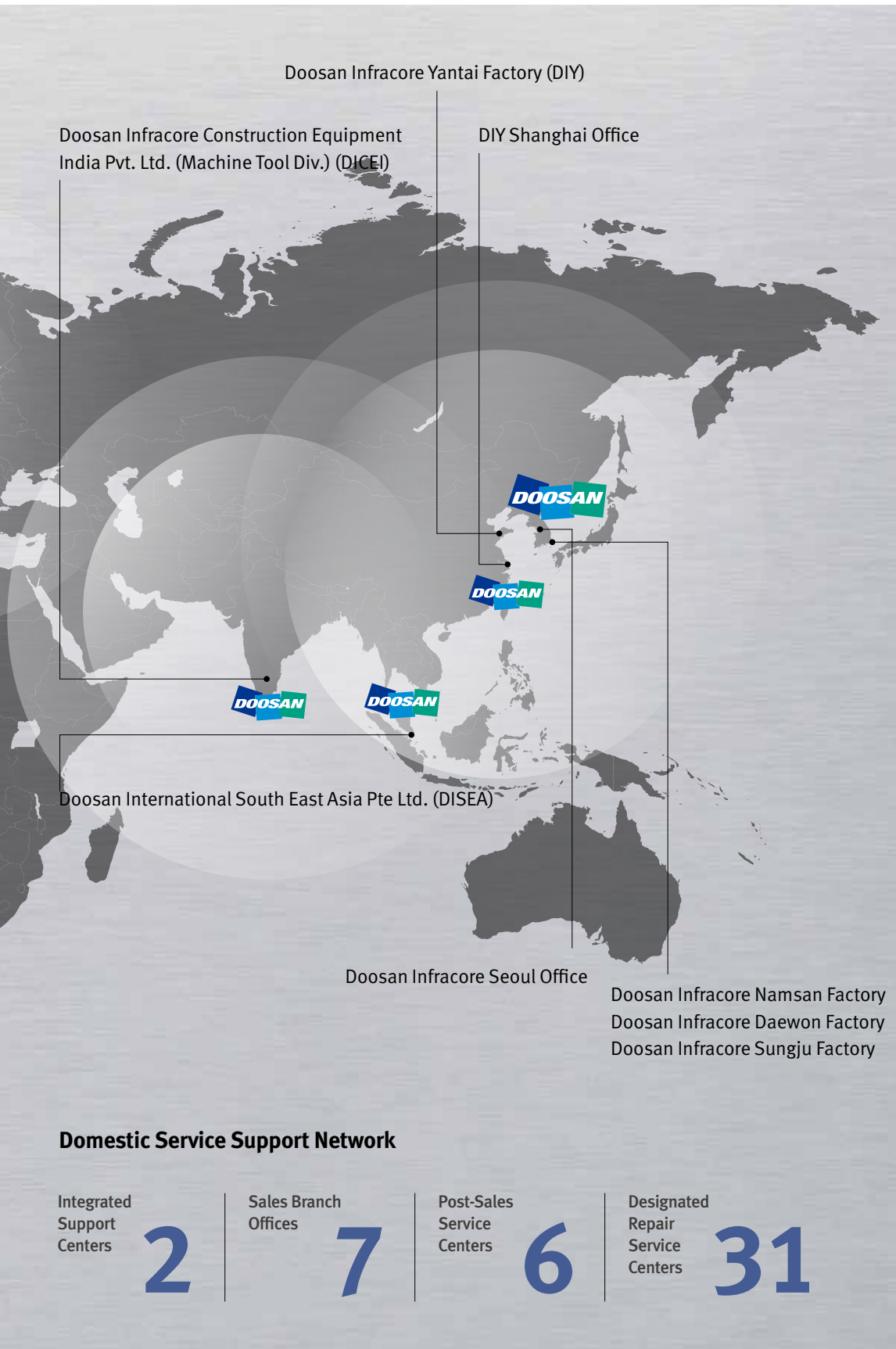

Customer Support Service

We help customers to achieve success by providing a variety of professional services from pre-sales consultancy to post-sales support.

Supplying Parts



- Supplying a wide range of original Doosan spare parts
- Parts repair service

Field Services



- On site service
- Machine installation and testing
- Scheduled preventive maintenance
- Machine repair

Technical Support



- Supports machining methods and technology
- Responds to technical queries
- Provides technical consultancy

Training



- Programming / machine setup and operation
- Electrical and mechanical maintenance
- Applications engineering

Major Specifications

HM 1000/1250/1250W

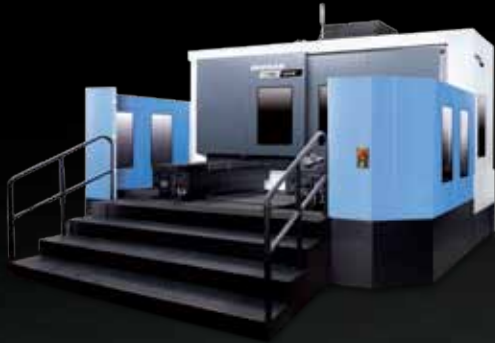

Description		Unit	HM 1000	HM 1250	HM 1250W
Travels	X-axis	mm (inch)	2100 (82.7)		
	Y-axis	mm (inch)	1250 (49.2)	1500 (59.1)	1400 (55.1)
	Z-axis	mm (inch)	1250 (49.2)	1500 (59.1)	1400 (55.1)
	W-axis	mm (inch)	-	-	300 (11.8)
Table	Table size	mm (inch)	1000 x 1000 {1250 x 1000} (39.4 x 39.4 {49.2 x 39.4})*	1250 x 1250 {1250 x 1000}* (49.2 x 49.2 {49.2 x 39.4})*	
	Loading capacity	kg (lb)	3000 {5000}* (6613.8 {11023.0}*)		5000 (11023.0)
	Max. workpiece size	-	1° {0.001"}*		
Spindle	Max. spindle speed	r/min	6000 {6000 / 8000}*		3000
	Max. spindle torque	N·m (ft·lb)	1989.4 {3687 / 1410}* (1468.2 {2721.0 / 1040.6}*)		1910 (1409.6)
	Spindle motor power	kW (Hp)	26 / 22 {37 / 30, 26 / 22}* (34.9 / 29.5 {49.6 / 40.2, 34.9 / 29.5}*)		45 / 37 (60.3 / 49.6)
Machine Dimensions	Length x Width	mm (inch)	9657 x 5822 (380.2 / 229.2)	10530 x 5822 (414.6 / 229.2)	11526 x 5822 (453.8 / 229.2)
	Height	mm (inch)	3885 (153.0)	4130 (162.6)	4581 (180.4)
	Weight	kg (lb)	29000 (63933.1)	31000 (68342.3)	33000 (72751.5)
CNC	NC system	-	FANUC 31i		

* { } : Option



Doosan Machine Tools

<http://www.doosanmachinetools.com>

Optimal Solutions for the Future

Head Office

Doosan Tower 20th FL., 275, Jangchungdan-Ro
(St), Jung-Gu, Seoul
Tel +82-2-3398-8693 / 8671 / 8680
Fax +82-2-3398-8699

Doosan Infracore America Corp.

19A Chapin Rd., Pine Brook, NJ 07058, U.S.A.
Tel +1-973-618-2500
Fax +1-973-618-2501

Doosan Infracore Germany GmbH

Emdener Strasse 24, D-41540 Dormagen,
Germany
Tel +49-2133-5067-100
Fax +49-2133-5067-001

Doosan Infracore Yantai Co., LTD

13 Building, 140 Tianlin Road, Xuhui District,
Shanghai, China (200233)
Tel +86-21-6440-3384 (808, 805)
Fax +86-21-6440-3389

Doosan Infracore Construction Equipment India Pvt. Ltd. (Machine Tool Div.)

106 / 10-11-12, Amruthahalli, Byatarayanapura,
Bellary road, Bangalore-560 092, India
Tel +91-80-4266-0122 / 121 / 100

Doosan International South East Asia Pte Ltd.

42 Benoi Road, Jurong 629903, Singapore
Tel +65-6499-0200
Fax +65-6861-3459



* For more details, please contact Doosan.

* The specifications and information above-mentioned may be changed without prior notice.