



Optimal Solutions for the Future

NHP series



**High-Speed,
High-Productivity
Horizontal
Machining Center**

NHP series

NHP 5500

NHP 6300

NHP 8000

ver. EN 160516 SU

Basic information

Basic Structure
Cutting
Performance

Machine Information

Standard/Optional
Specifications
Applications
Diagrams
Machine & NC Unit
Specifications

Customer Support



NHP series

The NHP Series will enhance your productivity with its high speed, powerful cutting performance, and world class specification. Its one piece bed structure equipped with a step guideway further strengthens rigidity, while its rapid traverse rate delivers excellent productivity. Furthermore, the NHP Series is also equipped with various user-convenience functions.



Contents

02 Product Preview

Basic information

04 Basic Structure

08 Cutting Performance

Machine Information

09 Standard/Optional Specifications

10 Applications

18 Diagrams

24 Machine & NC Unit Specifications

26 Customer Support

High rigidity one-piece bed

The high rigidity one-piece bed supports heavy duty cutting with the adoption of Finite Element Method (FEM) analysis.

High productivity and reliability

The NHP Series rapid traverse rate has been further increased with the adoption of a high speed axis drive system. The servo driven automatic tool changer (ATC) and automatic pallet changer (APC) improve parts durability and maintainability. The increased APC cycle time also improves productivity. The APC system provides an optional increased pallet size on the NHP550 and 6300 models.

User-friendly functions

Various new user-friendly functions have been introduced to reduce the operator's work load.



Machine Structure

Step guide-type high-rigidity bed supports even-higher productivity.

Step-Guide-Type High-Rigidity Bed Structure

The main body is designed as a double-wall structure to prevent coolant leakage and achieves excellent maintainability.

The step-guide bed structure supporting the column realizes high rigidity.

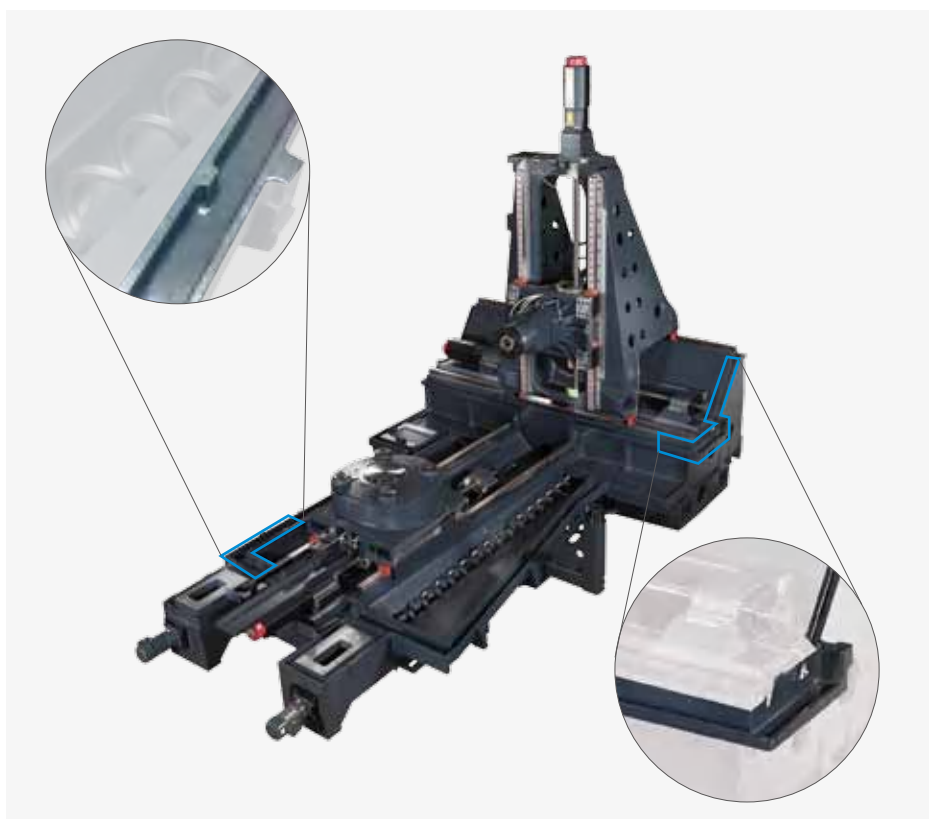

Basic information

Basic Structure
Cutting
Performance

Machine Information

Standard/Optional Specifications
Applications
Diagrams
Machine & NC Unit Specifications

Customer Support



Feed Axes

All the axes are fitted with roller-type LM Guideways and low-noise, high-precision ball screws to enhance durability.

Stable, Fast Feed Axis Structure

All the axes are equipped with roller-type LM Guideways and 3-row angular thrust bearings at both ends to improve structural reliability.

Low-noise, high-precision ball screws support high-accuracy axis feed.

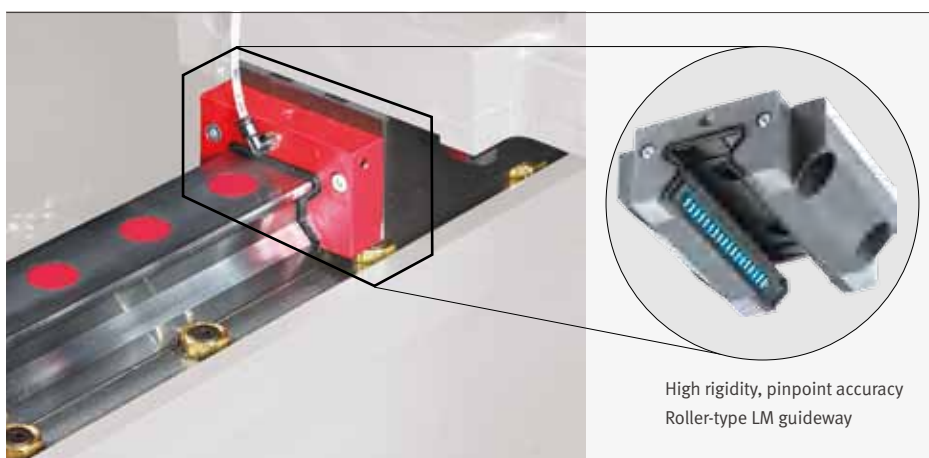

High rigidity, pinpoint accuracy
Roller-type LM guideway

	NHP 5500	NHP 6300	NHP 8000
Travel distance (X / Y / Z) (mm(inch))	800 / 750 / 850 (31.5 X 29.5 x 33.5)	1050 / 900 / 1000 (41.3 x 35.4 x 39.4)	1400 / 1200 / 1370 (55.1 x 47.2 x 53.9)
Rapid travel speed (rpm)	60		50



Spindle

The high-speed spindle is designed to minimize vibration and thermal error while offering the fastest acceleration and deceleration, thereby guaranteeing superior cutting performance compared to the competitors.

High-Speed, High-Performance Spindle

Designed to minimize vibration and thermal error while offering rapid acceleration and deceleration, the spindle guarantees excellent cutting performance from steel to nonferrous metal parts. Thanks to its increased rigidity, the spindle supports various machining from high speed cutting to low speed heavy cutting. In addition, the high-torque, high-speed built-in spindle delivers increased torque.



	Speed (r/min)	Power (kW (HP))	Torque (N-m (ft-lbs))	Type
Standard	10000	45/25 (60.3/33.5)	600 (442.8)	ISO #50
Option	6000	37/22 (49.6/29.5)	809 (597.0)	
Option	15000	37/30 (49.6/40.2)	398 (293.7)	

Spindle Cooling System

An oil cooler system is provided as a standard feature for long-term, continuous operation at high speed. The oil is cooled down in the cooler before circulating around the spindle bearings and built-in motor to minimize thermal error and deliver high-precision cutting.

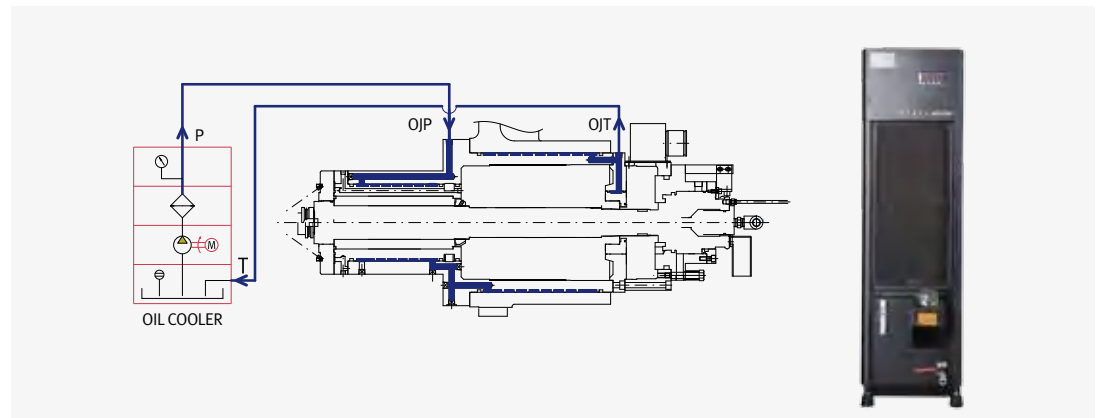

Dual-Face Tool Locking System

Tool rigidity is enhanced by firm clamping by the spindle, while tool life cycle and cut-surface roughness are improved due to reduced vibration realized by 2-face locking.





Automatic Tool Changer (ATC)

The servo-driven ATC provides high reliability and reduces tool change time.

Servo-driven ATC

The ATC is capable of handling pot-type tools weighing up to 25kg(25lb) and chain-type tools weighing up to 30kg(66.1lb) at high speed using a servo motor, and fast tool indexing and spindle positioning.

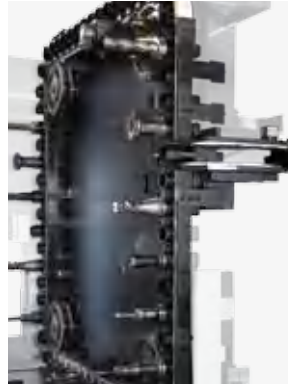

Specifications (Max. tool diameter x max. tool length)				
Model	Standard (mm(inch))		Optional (mm(inch))	
	BT/CT/DIN	HSK	BT/CT/DIN	HSK
NHP 5500	320 x 530(12.6 x 20.9)	320 x 600 (12.6 X 23.6)	-	
NHP 6300	320 x 630(12.6 X 24.8)	320 x 700(12.6 X 27.6)	-	
NHP 8000	320 x 630(12.6 X 24.8)	320 x 700(12.6 X 27.6)	320 x 800 (12.6 X 31.5)	320 x 800 (12.6 X 31.5)

Tool change time (tool weight of less than 12 kg)		
Model	Tool to tool	Chip to chip
NHP 5500	2 s	5 s
NHP 6300		5.4 s
NHP 8000		6.2 s

Machine Information

Standard/Optional Specifications
Applications
Diagrams
Machine & NC Unit Specifications

Customer Support

Convenient Short Tool Cutting

The distance between the spindle and the center of the pallet has been reduced for heavier-duty cutting with shorter tools.

Features

- Increased tool rigidity with a larger diameter
- Innovative improvement of ATC repeatability
- Minimal Z axis displacement at high speed
- Increased tool service life

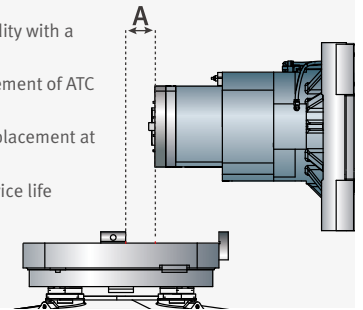

Tool Magazine

40 tools as a standard feature, in addition to various options.

Tool magazine for diverse types of tools, including pot, chain and matrix tool types

The NHP Series provides 40 tools as a standard feature, and up to 376 tools as an option.





Automatic Pallet Changer (APC)

The servo-driven APC boasts high reliability with its stable, accurate performance and reduced rejection ratio.

Improved Pallet and APC System

APC system achieves increased productivity with fast and accurate pallet change. In addition to its excellent reliability, the improved APC has more space for the operator's convenience.

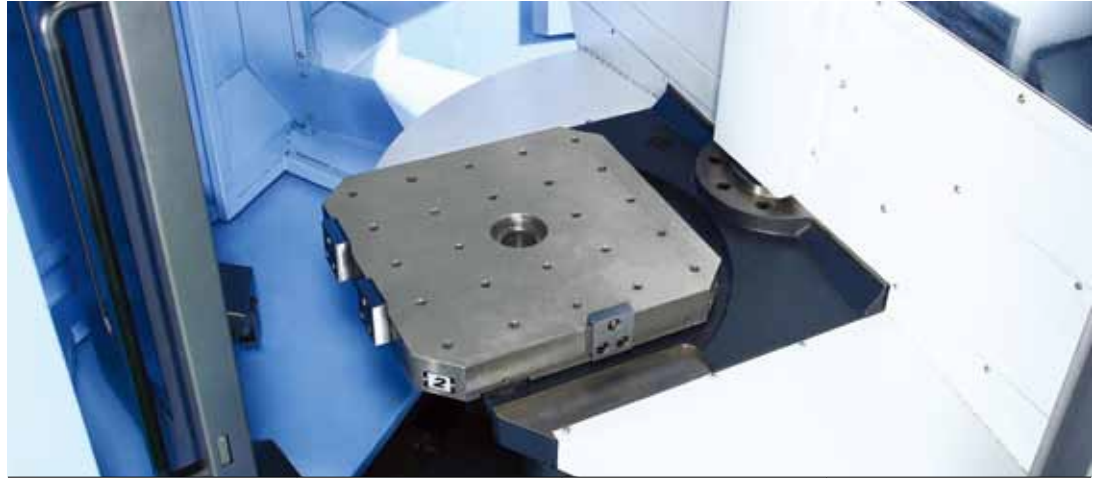

	NHP 5500	NHP 6300	NHP 8000
Pallet change time	8.5 s	12 s	16 s

Cone Air Blower

As a mechanism designed for precise pallet position repeatability, the air blower injects high pressure air into the location cones connecting the table to the pallet. This removes chips from the locating surfaces and ensures highly accurate pallet positioning.

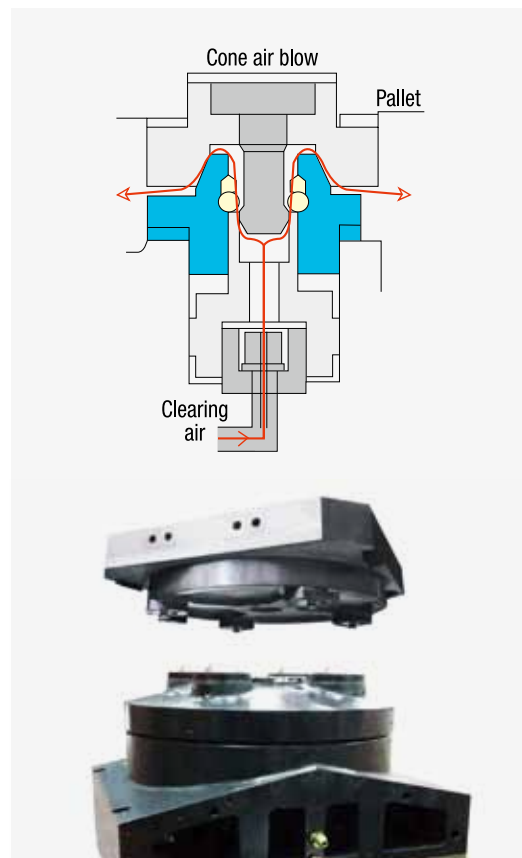

Max. Workpiece Size

The NHP Series provides more space for heavier and larger workpieces.

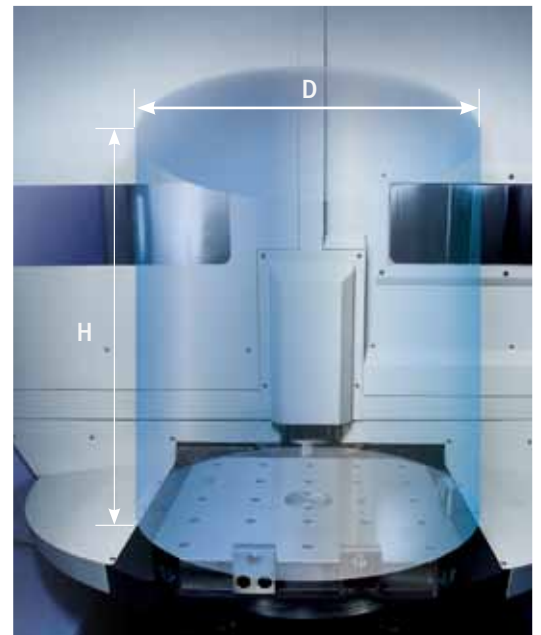

Max. workpiece size (D X H)

NHP 5500	Ø 850 x 1100 mm(33.5 X 43.3 inch)
NHP 6300	Ø 1050 x 1350 mm(41.3 X 53.1 inch)
NHP 8000	Ø 1450 x 1550 mm(57.1 X 61.0 inch)

Max. workpiece weight (W)

NHP 5500	800 kg(1763.7 lb)
NHP 6300	1500 kg(3306.9 lb)
NHP 8000	2000 kg(4409.2 lb)



Superior Machining Performance

The NHP Series realizes excellent machining performance thanks to its improved structure and comprehensive tooling system.

Basic information

Basic Structure
Cutting
Performance

Machine Information

Standard/Optional Specifications
Applications
Diagrams
Machine & NC Unit Specifications

Customer Support

Higher Cutting Power

High-rigidity machining can be carried out with precision accuracy and diverse functions.

Cutting Capacity				
NHP series				
Face Mill_Carbon Steel (SM45C) [ø125mm(4.9inch) Face mill (BZ)]				
	Machining rate	Spindle speed	Feed rate	
Previous models	440 cm ³ /min	350 r/min	550 mm/min	
NHP series	700 cm ³ /min	500 r/min	1400 mm/min	
Tap_Carbon Steel (SM45C)				
	Machining rate	Spindle speed	Feed rate	
M42×P4.5		150 r/min	675 mm/min	
Drill_Carbon Steel (SM45C) [ø85mm(3.3inch) U-Drill (2Z)]				
	Machining rate	Spindle speed	Feed rate	
567 cm ³ /min		600 r/min	100 mm/min	

* The results, indicated in this catalogue are provides as example. They may not be obtained due to differences in cutting conditions and environmental conditions during measurement.

High Productivity

Improved cutting performance: mproved by more than 8 % compared to previous model

- Diesel engine cylinder block
- Material: Cast iron
- No. of tools used: 20



Cycle time

Previous model	977 s
NHP series	900 s ↓ 77 s

Down
8%

Optional Accessories

● Standard ○ Optional X N/A

Diverse optional devices and features are available to meet every customer's specific requirements.

Description		Features	NHP 5500	NHP 6300	NHP 8000		
1	Tool Magazine	40 tools	●	●	●		
2		60 tools	○	○	○		
3		90 tools	○	○	○		
4		120 tools	○	○	○		
5		150 tools	○	○	○		
6	Type of tool shank	BT50	●	●	●		
7		CAT50	○	○	○		
8		DIN50	○	○	○		
9		HSK	○	○	○		
10	Mist Collector	Mist Collector	○	○	○		
11	Spindle	6000 r/min	37 / 22 kW (49.6 / 29.5 Hp)	○	○	○	
12		10000 r/min	45 / 25 kW (60.3 / 33.5 Hp)	●	●	●	
13		15000 r/min	37 / 30 kW (49.6 / 40.2 Hp)	○	○	○	
14		Spindle air curtain		●	●	●	
15	Spindle motor power	45 / 25 kW (60.3 / 33.5 Hp)		●	●	●	
16		37 / 22 kW (49.6 / 29.5 Hp)		○	○	○	
17		37 / 30 kW (49.6 / 40.2 Hp)		○	○	○	
18	Hydraulic fixtures	Hydraulic fixture line	2X2	○	○	○	
19			4X4	○	○	○	
20			6X6	○	○	○	
21			8X8	○	○	○	
22		Hydraulic fixture unit		○	○	○	
23	Automatic workpiece measurement device	OMP60_RENISHAW		○	○	○	
24		RMP60_RENISHAW		○	○	○	
25	Auto tool measuring device	BK MIKRO		○	○	○	
26		NEEDLE SWING TYPE		○	○	○	
27		OMRON (Limit Switch Type)		○	○	○	
28		TS27R		○	○	○	
29		NC 4		○	○	○	
30	Accuracy	Linear scale (X-axis)		○	○	○	
31		Linear scale (Y-axis)		○	○	○	
32		Linear scale (Z-axis)		○	○	○	
33	Chip Handling System	Chip conveyor	HINGED type	○	○	○	
34			SCRAPER type	○	○	○	
35			DRUM type	○	○	○	
36		Chip bucket		○	○	○	
37	Coolant	FLOOD		●	●	●	
38		FLUSHING		●	●	●	
39		SHOWER		○	○	○	
40		TSC	1.5 KW 2.0 MPA		○	○	○
41			3.0 KW 3.0 MPA		○	○	○
42			7.5 KW 7.0 MPA		○	○	○
43		Coolant gun		○	○	○	
44		Oil skimmer		●	●	●	
45		MQL System		○	○	○	
46	Table	Index table (1° control)		●	●	●	
47		Rotary table (0.001° control)		○	○	○	
48	Pallet	Tap pallet		●	●	●	
49		T-SLOT pallet		○	○	○	
50	Air	Pallet air seat		○	○	○	
51		AIR GUN		○	○	○	
52	MPG	Portable MPG		●	●	●	

Basic information

Basic Structure
Cutting
Performance

Machine Information

Standard/Optional Specifications
Applications
Diagrams
Machine & NC Unit Specifications

Customer Support

Diversified Options

Chip disposal is very important to productivity and the work environment. To meet this requirement, the NHP Series enhances chip disposal performance and improves the work environment.

Chip Conveyor option



Scraper type



Hinge type



Drum filter type



Chip conveyor

Chip Disposal System



Flushing coolant



Flood coolant



Shower coolant option



Coolant gun option

Measurement Systems



Auto tool damage detection device I Option (BK 9)



Auto tool damage detection device II option (OMRON)



Automatic tool measuring device(TS 27R) option



Coolant spray gun on the spindle head



Screw conveyor



Spindle-through coolant spray device option

Environmentally-friendly Devices



Oil skimmer



Mist collector option



MQL system option



Misting device



Application

We offer a wide range of solutions that can be optimized to suit each customer's needs.

Clamping Fixtures

The following hydraulic and pneumatic fixture options are available for setting up workpieces:

A variety of preparations for workpiece clamping fixtures (hydraulic/pneumatic) option

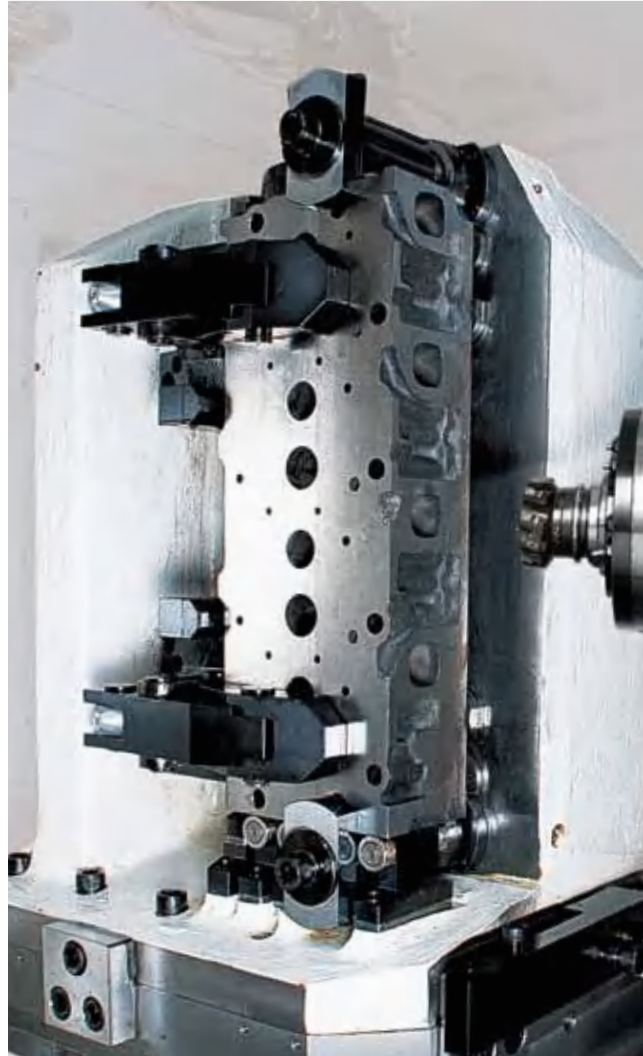

Hydraulic/pneumatic fixture pot

- A/B Line : 2, 4, 6, 8 Pairs
(Including solenoid valve)
- P/T Line : 2, 4, 6, 8 Pairs
(Excluding solenoid valve)

Clamping fixture hydraulic motor

- 2.2 kW(3.0 HP) / 7MPa
- 3.7 kW(5.0 HP) / 15MPa
- 5.5 kW(7.4 HP) / 21MPa

※Please provide us with detailed specifications on the order sheet.

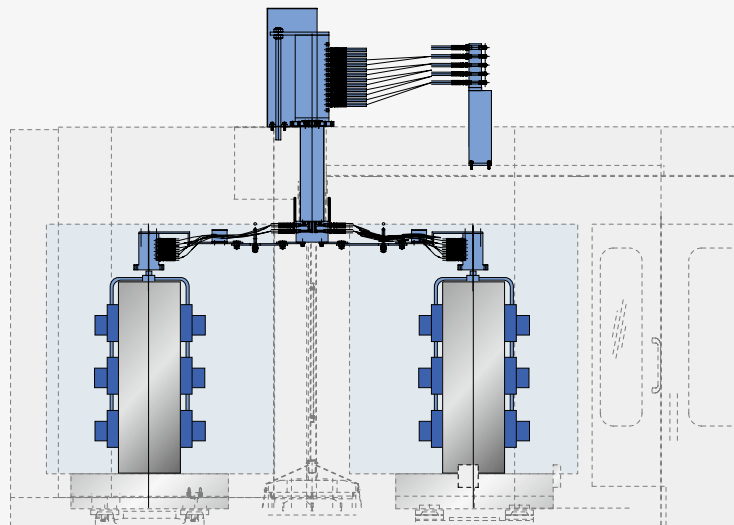

The overhead connecting system allows pallet change and table index cycles whilst maintaining hydraulic/pneumatic connections to fixtures .



Pallet Extension System

Basic information

Basic Structure
Cutting
Performance

Machine Information

Standard/Optional Specifications
Applications
Diagrams
Machine & NC Unit Specifications

Customer Support

Doosan's linear pallet system (LPS) and multi-pallet system (MPS) provides users with maximized productivity, rapid installation and commissioning, and easy maintainability.

Doosan Linear Pallet System [LPS II] option

Designed to provide users with an optimised system, the LPSII linear pallet systems designed and constructed by Doosan, offering outstanding flexibility, including system extension and layout change.

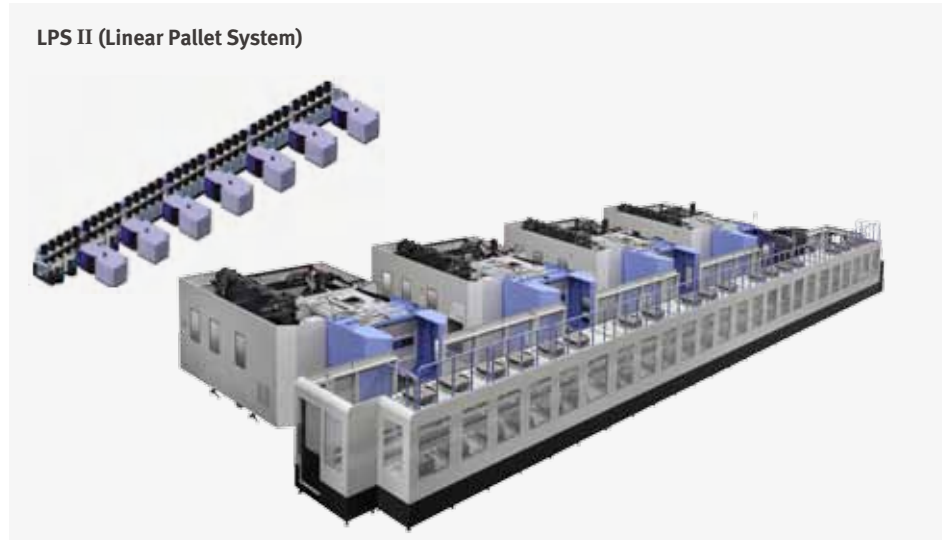

LPS II Model	LPS 500 II		LPS 630 II	LPS 800 II
Available Model	HP 5100 II	NHP 5500	NHP 6300	NHP 8000
Forking type	Twin Fork type			
No. of machines	1 - 7			
No. of setup stations	1 - 4			
No. of pallets	12 ~ 70		10 ~ 70	8 ~ 70
Dimensions (L x W)	7824 x 2400 mm (308.0 X 94.5 inch)		7904 x 785 mm (311.2 X 30.9 inch)	8952 x 3500 mm (352.4 X 137.8 inch)

Features

- Easy for system extension
- Sufficient workpiece space for high level of work efficiency
- Stable and efficient system operation
- Faster installation and commissioning
- Applicable to all HMC Series machines
- Excellent maintainability

LPS Standard Control Software

- Easily-storable basic information for flexible production.
- Platform management software for rapid production and changes in quantity.
- LPS management solution for fast and flexible production and sudden changes in quantity.

Doosan Production Management System [DPMS]

The DPMS is an operating system designed to ensure effective control and management of the LPS. The main window provides a solution that enables a flexible and rapid response to changes in output.

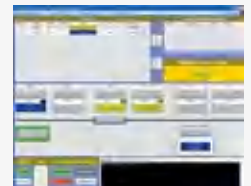

System Outline

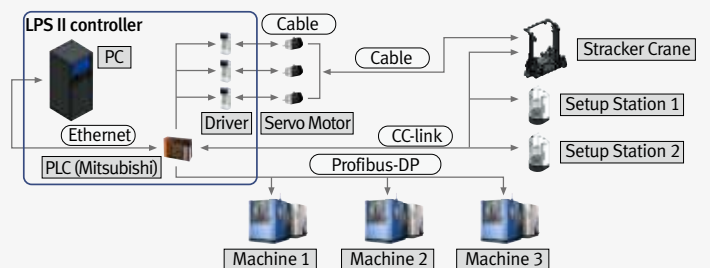

Doosan Multi-pallet Station [MPS] option

Compared with standard machines that use 2-pallet type APCs, the MPS can automatically handle 7 to 9 pallets for an extended period. This function enables small quantity batch production using machining scheduling.

Doosan Multi-pallet Station [DMPS]

The DMPS is an operating system for effective control and management of the MPS. The functions of the DMPS include scheduled operation, data input, and setting change.

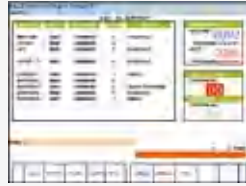

7 MPS

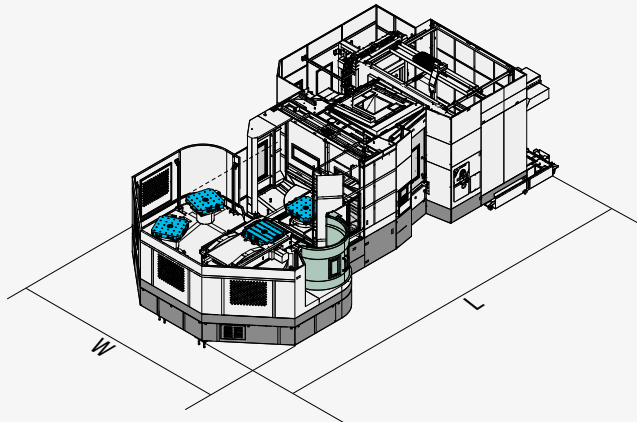

9 MPS

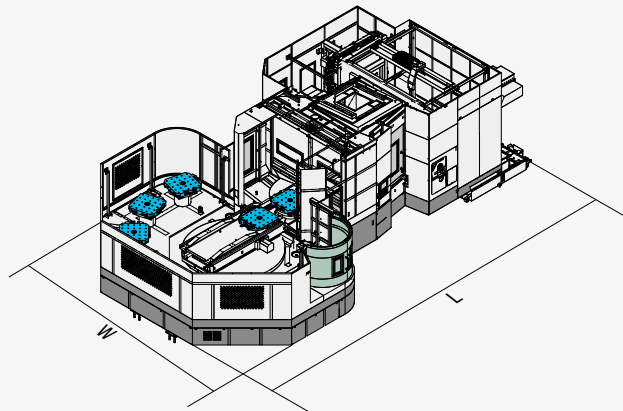

System Options

	NHP 5500		NHP 6300		NHP 8000	
	7 - MPS	9 - MPS	7 - MPS	9 - MPS	7 - MPS	9 - MPS
No. of pallets (pcs.)	7	9	7	9	7	9
Foot print (Length) (mm(inch))	8460(333.1)	9150(360.2)	9720(382.7)	10790(424.8)	12027.5(473.5)	12738.5(501.5)
Foot print (Width) (mm(inch))	4230(166.5)	4420(174.0)	4820(189.8)	5520(217.3)	6462(254.4)	6706(264.0)

* Chip conveyor and MPS foot board are excluded.



User Convenience

Ergonomic design guarantees users' convenience and safety.

Basic information

Basic Structure
Cutting
Performance

Machine Information

Standard/Optional Specifications
Applications
Diagrams
Machine & NC Unit Specifications

Customer Support

User-oriented Design

Internal footings and an anti-door-lock function are provided to prevent the operator from being locked in the machine and to guarantee the operator's safety. The centralized service unit and screen panel enhance the operator's convenience.

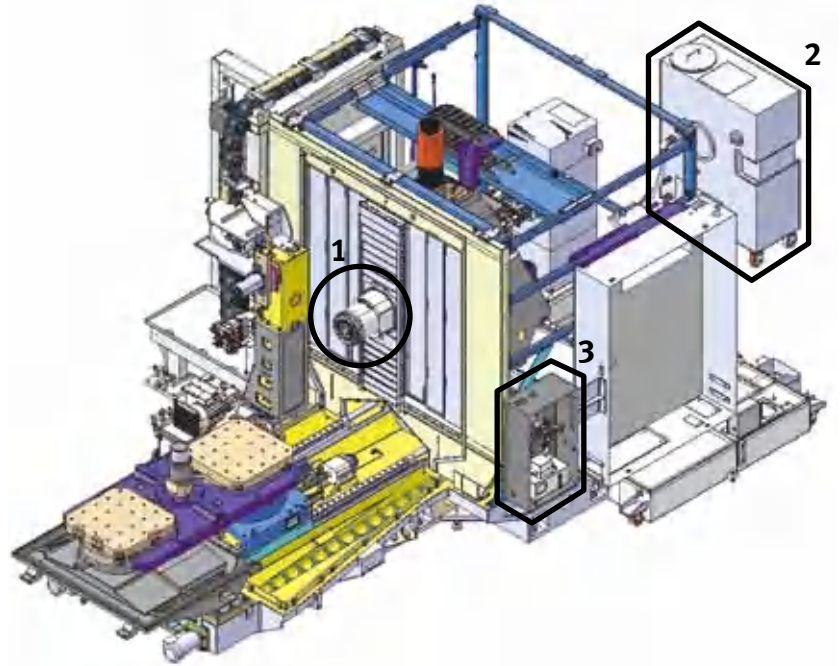

1.
Flushing system to remove chips from the spindle top and slide cover.



2.
Coolant through spindle function for enhanced productivity **option**



3.
Centralized utility service unit
The utilities service unit is centralized for convenient maintainability.

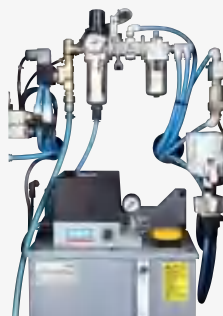

ATC screen panel provides easy tool data entry at the tool magazine area



Safety has been improved with machine internal footings



Anti-door lock device





User Convenience

User convenience has been significantly enhanced with a new operation panel.

Simple and Convenient Operation Panel

The operator's panel has been redesigned and integrated for better usability. Additional, customized function switches (option) can be provided to maximize the operator's convenience.



Clamping fixture lock/unlock button, counter, timer and other special optional buttons can be provided.

The buttons are separated by partitions in order to prevent erroneous operation of the buttons.

Swiveling Operating Panel



The operating panel can swivel by 90°, and displays various alarm messages concerning machine and controller error, enhancing the operator's convenience.

PCMCIA Card

The PCMCIA card enables uploading and downloading of the NC program, NC parameters, tool information, and ladder programs, and also supports DNC operation.

Portable MPG

The portable MPG allows the user to set up workpieces more easily.



USB Port

Upload/download of NC software programs, NC parameters, tool information and ladder program using a USB drive is allowed, but DNC operation is not supported.





EOP Function

Basic information

Basic Structure
Cutting
Performance

Machine Information

Standard/Optional
Specifications
Applications
Diagrams
Machine & NC Unit
Specifications

Customer Support

Doosan's Easy Operation Package (EOP) supports the user with tool, help desk, operation, and pallet magazine functions among others.

EOP (Easy Operation Package)

Doosan's EOP supports the user with tool, help desk, operation, and pallet magazine functions among others to maximize operational efficiency and user convenience.

Tool Support Functions



Tool management I

- Tool magazine control
- Tool state display
- Fastems Tool Add/Remove Function **option**

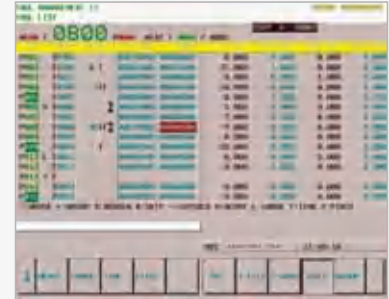

Tool management II **option**

- Tool magazine control
- Tool life management
- Tool life prediction
- Tool state control
- Balluff Tool ID function



Tool load monitor **option**

- Detection of tool damage
- Detection of abnormalities during operation
- Detection of no-load air cutting



ATC/APC panel

- ATC manual
- APC manual

Operation Support Functions



Operation rate

- Measure various machine operating rate
- Support 3 shift operation
- calculate and save 30 days operating rate
- Show data for a specific period



PMC switch

- Operation panel function (option)
- Substitutes toggle switches
- NC option software

Help Desk Functions

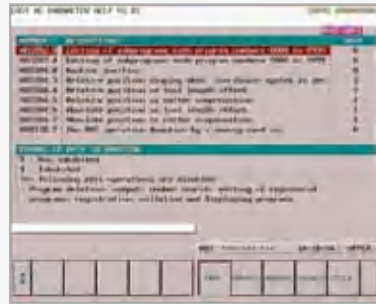

Easy NC parameter

- Help for major parameters
- Show parameter settings



Calculator

- Calculator function
- 4 arithmetical operations
- Supports mathematical functions

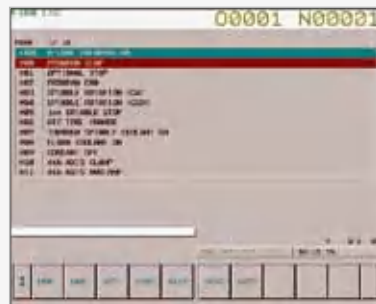

M Code List

- List of major M codes

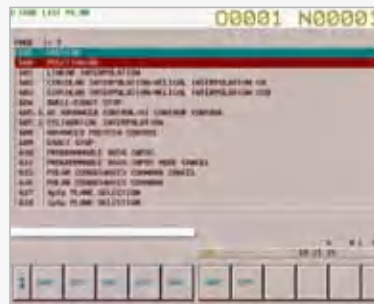

G Code List

- List of major G codes

Pallet Magazine Support Functions

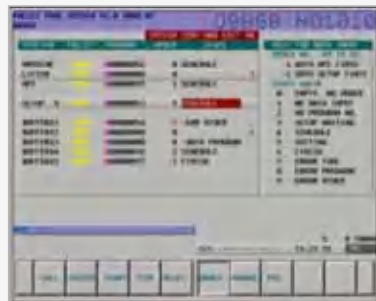

Multi-pallet station option

- Control MPS operation
- Display information on MPS PMG
- Set-up of machining schedule
- Auto Call function
- Manual operation and coordinate setting function



APC setting

- 2-pallet APC operation screen

Spindle Power – Torque Curve

Basic information

Basic Structure
Cutting
Performance

Machine Information

Standard/Optional
Specifications
Applications
Diagrams
Machine & NC Unit
Specifications

Customer Support

6000 r/min

Spindle Motor:

37 / 22 kW (49.6 / 29.5 Hp) **option**

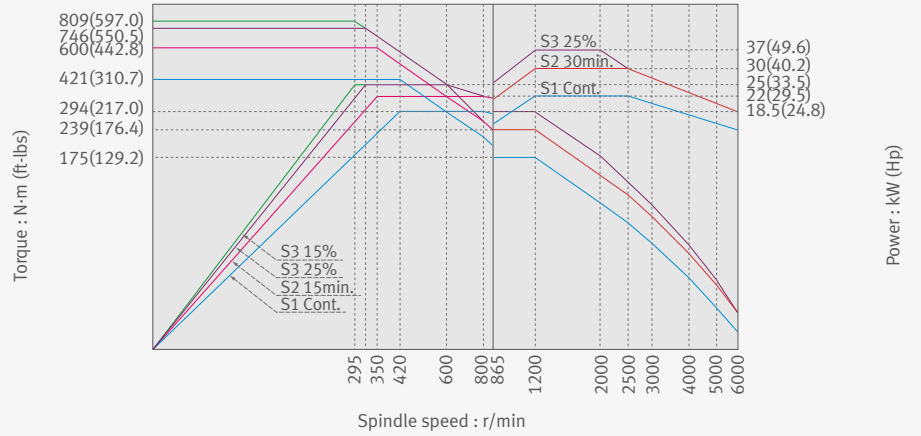

10000 r/min

Spindle Motor:

45 / 25 kW (60.3 / 33.5 Hp)

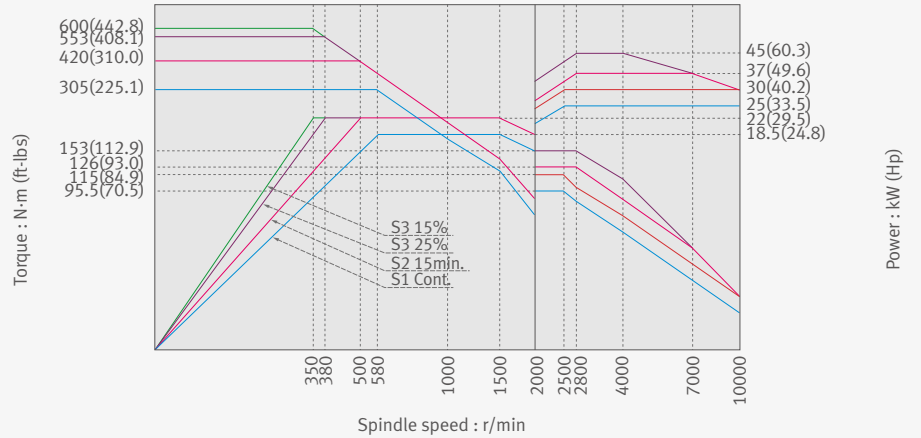

15000 r/min

Spindle Motor:

37 / 30 kW (49.6 / 40.2 Hp) **option**

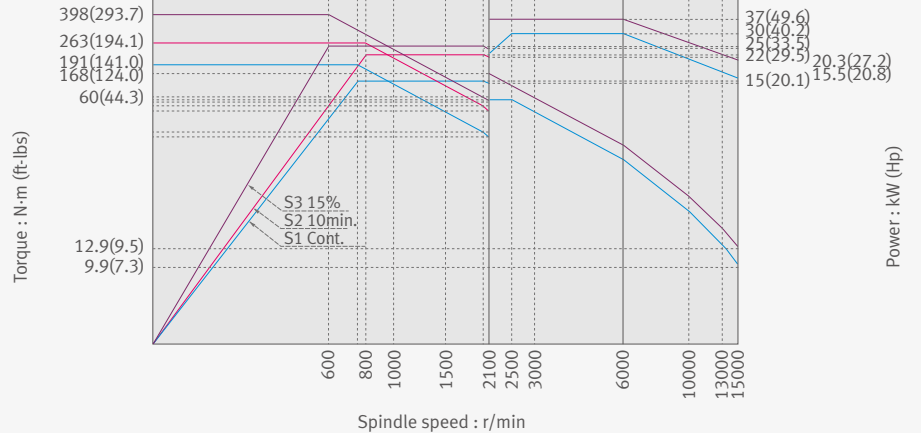

External Dimensions

NHP 5500

Unit: mm(inch)

Top View

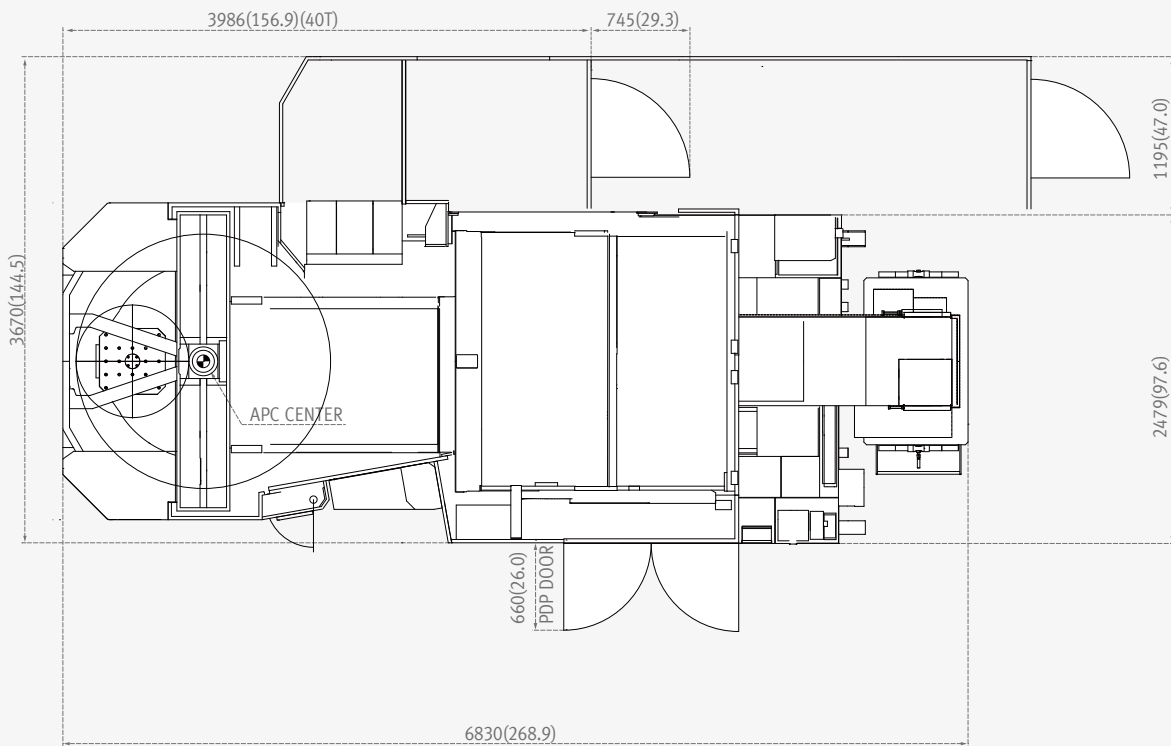

Side View

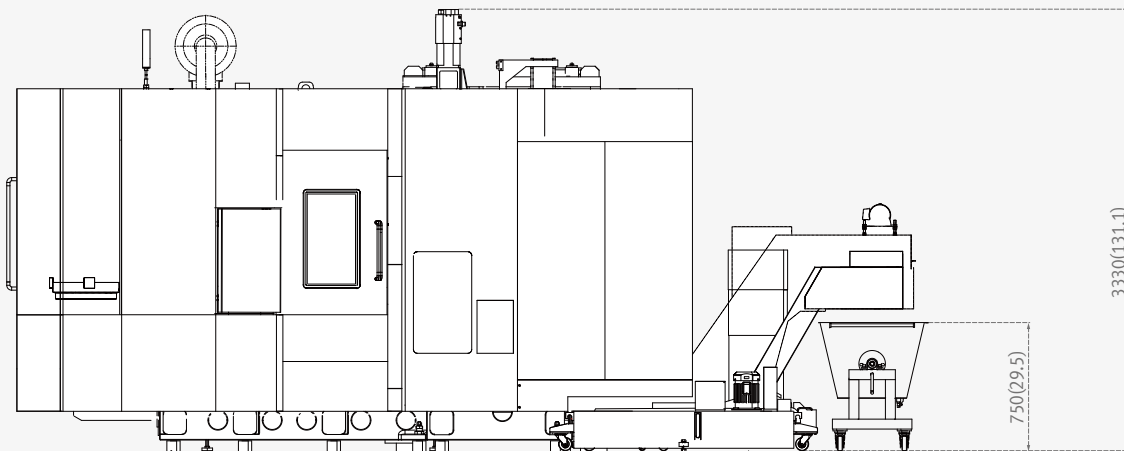

External Dimensions

Basic information

NHP 6300

Unit: mm(inch)

- Basic Structure
- Cutting
- Performance

Machine Information

- Standard/Optional Specifications
- Applications
- Diagrams
- Machine & NC Unit Specifications

Customer Support

Top View

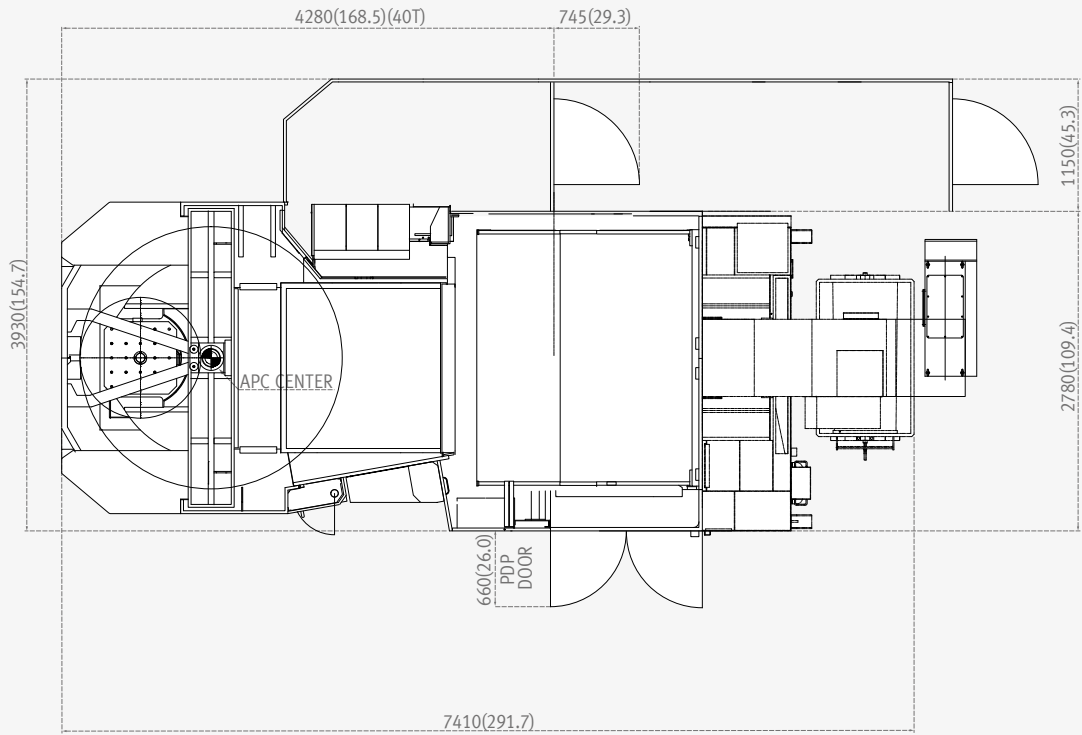

Side View

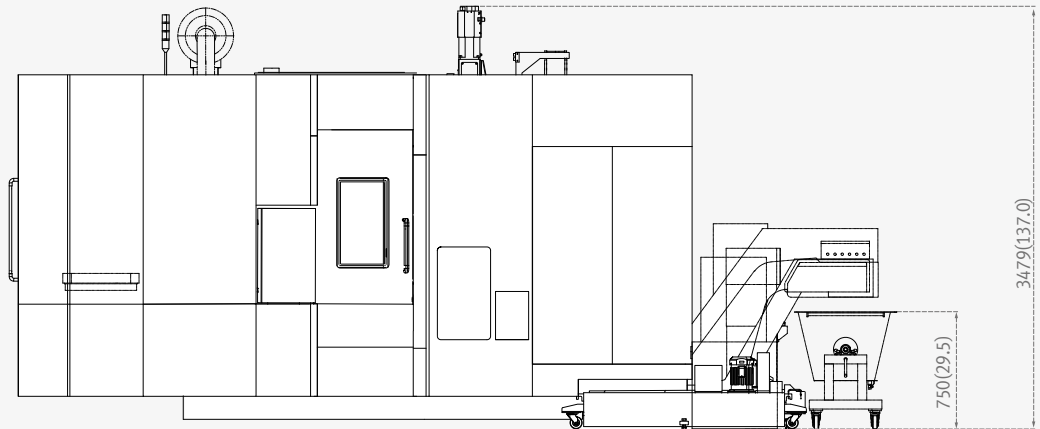

External Dimensions

NHP 8000

Unit: mm(inch)

Top View

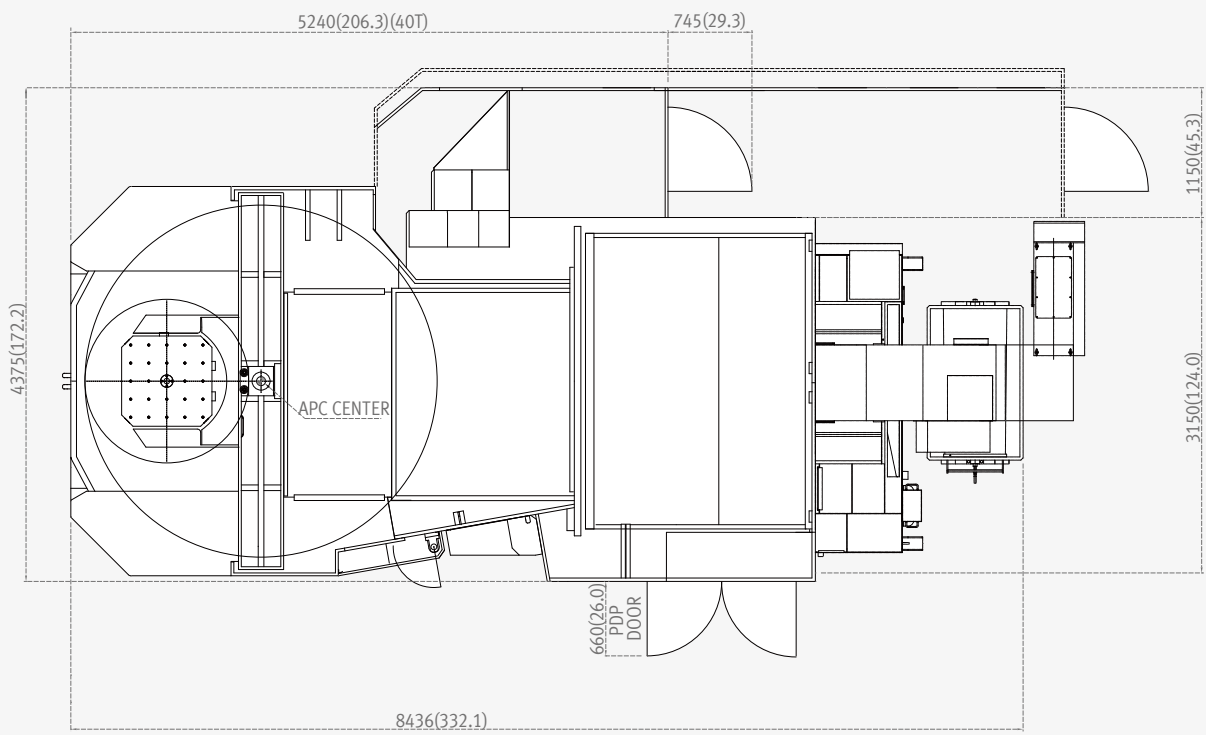

Side View

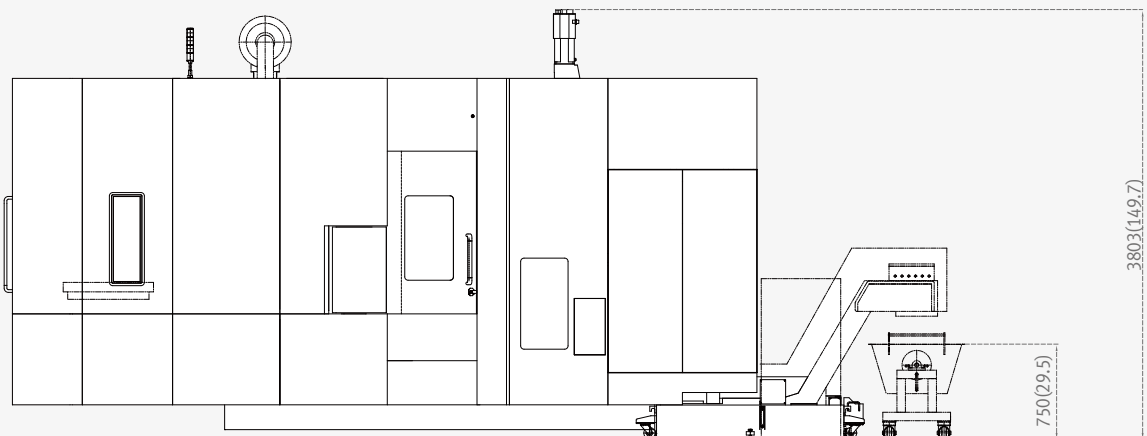

Table External Dimensions

Basic information

- Basic Structure
- Cutting
- Performance

NHP 5500/6300/8000

NHP 5500

Unit: mm(inch)

Standard Specifications (500×500(19.7×19.7))

Optional Specifications (630×630(24.8×24.8))

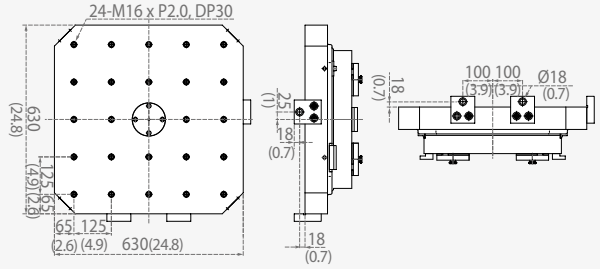
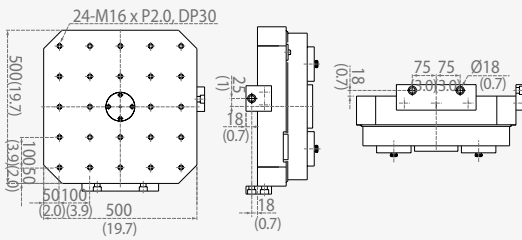

Machine Information

- Standard/Optional Specifications
- Applications
- Diagrams
- Machine & NC Unit Specifications

Customer Support

NHP 6300

Unit: mm(inch)

Standard Specifications (630×630(24.8×24.8))

Optional Specifications (800×800(31.5×31.5))

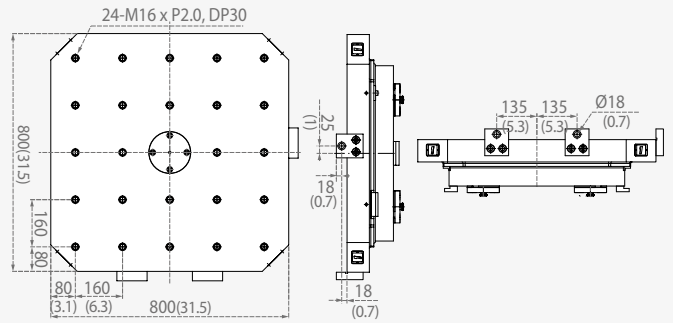
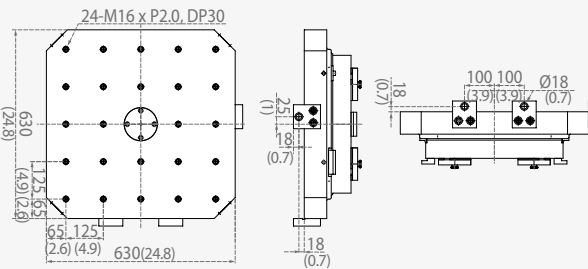

NHP 8000

Unit: mm(inch)

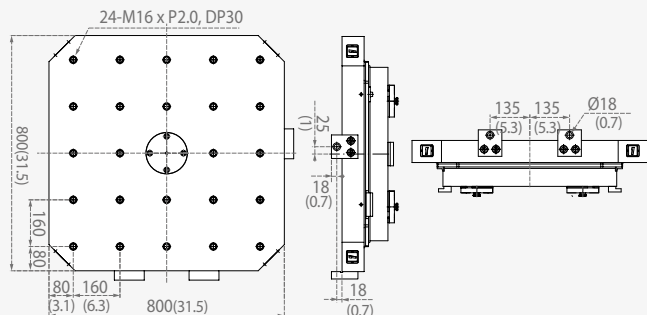

Workpiece working area

NHP 5500/6300/8000

Workpiece working area

Unit: mm(inch)

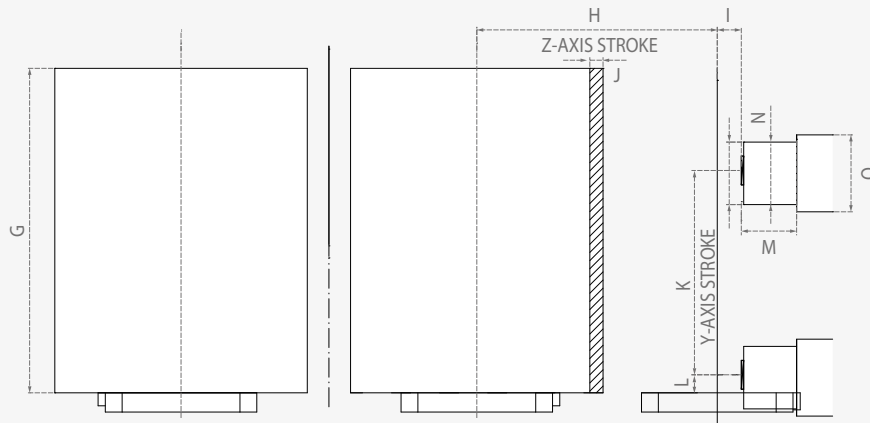
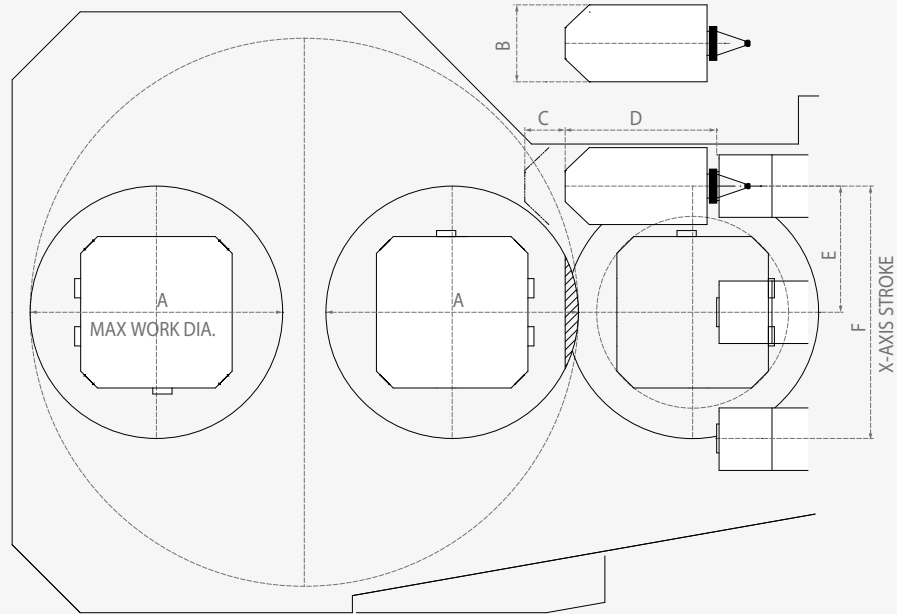

Model	A	B	C	D	E	F	G	H	I	J	K	L	M	N	O
NHP 5500	Ø850 (33.5)	Ø320 (12.6)	168 (6.6)	530 (20.9)	400 (15.7)	800 (31.5)	1100 (43.3)	850 (33.5)	100 (3.9)	5 (0.2)	750 (29.5)	75 (3.0)	230 (9.1)	Ø260 (10.2)	Ø320 (12.6)
NHP 6300	Ø1050 (41.3)	Ø320 (12.6)	168 (6.6)	630 (24.8)	525 (20.7)	1050 (41.3)	1350 (53.1)	1000 (39.4)	100 (3.9)	55 (2.2)	900 (35.4)	75 (3.0)	230 (9.1)	Ø260 (10.2)	Ø320 (12.6)
NHP 8000	Ø1450 (57.1)	Ø320 (12.6)	168 (6.6)	630 (24.8)	700 (27.6)	1400 (55.1)	1550 (61.0)	1370 (53.9)	150 (5.9)	5 (0.2)	1200 (47.2)	75 (3.0)	230 (9.1)	Ø260 (10.2)	Ø320 (12.6)

Machine Specifications

Basic information

Basic Structure
Cutting
Performance



Machine Information

Standard/Optional
Specifications
Applications
Diagrams
Machine & NC Unit
Specifications

Customer Support

Description		Unit	NHP 5500	NHP 6300	NHP 8000		
Cutting Capacity	Travel distance	X-axis	mm(inch)	800(31.5)	1050(41.3)	1400(55.1)	
		Y-axis	mm(inch)	750(29.5)	900(35.4)	1200(47.2)	
		Z-axis	mm(inch)	850(33.5)	1000(39.4)	1370(53.9)	
	Distance from spindle nose to table center		mm(inch)	100-950(3.9-37.4)	100-1100(3.9-43.3)	150-1520(5.9-59.8)	
	Distance from spindle center to table top		mm(inch)	75-825(3.0-32.5)	75-975(3.0-38.4)	75-1275(3.0-50.2)	
Feed Rate	Rapid feed rate	X-axis	m/min	60		50	
		Y-axis	m/min	60		50	
		Z-axis	m/min	60		50	
	Cutting feed rate		mm/min	30000		25000	
Pallet	Pallet type		24-M16xP2.0				
	Pallet indexing angle		deg	1 {0.001}*			
	Max. loading capacity		kg(lb)	800(1763.7)	1500(3306.9)	2000(4409.2)	
	Max. workpiece size		mm(inch)	850 x 1100 (33.5 x 43.3)	1050 x 1350 (41.3 x 53.1)	1450 x 1550 (57.1 x 61.0)	
	Pallet size		mm(inch)	500 x 500 (19.7 x 19.7)	630 x 630 (24.8 x 24.8)	800 x 800 (31.5 x 31.5)	
Spindle	Max spindle speed		r/min	10000 {6000, 15000}*			
	Taper specifications			ISO #50, 7/24 TAPER			
	Max. torque		N·m(ft·lbs)	600 {809, 398}{442.8 {597.0, 293.7}}*			
Auto Pallet Changer (APC)	No. of pallets		ea	2			
	Pallet change time		s	8.5	12	16	
	APC indexing angle (rotation)		deg	90			
Automatic Tool Changer (ATC)	Tool shank type			BT50 {CAT50 / DIN50 / HSK-A100}*			
	Tool storage capacity	Pot type	ea	40 {60}*			
		Chain type	ea	{90 / 120 / 150}*			
		Matrix type	ea	{196 / 256 / 316 / 376}*			
	Max. tool diameter	40 / 60 tools	W/O adjacent tool	mm(inch)	320(12.6)		
			With adjacent tool	mm(inch)	125(4.9)		
		90 / 120 / 150 / 196 / 296 / 376 tools	W/O adjacent tool	mm(inch)	320(12.6)		
			With adjacent tool	mm(inch)	130(5.1)		
	Max. tool length		mm(inch)	530(20.9) (BT / CAT / DIN), 600(23.6) (HSK)	630(24.8) (BT / CAT / DIN), 700(27.6) (HSK)	630(24.8) (BT / CAT / DIN), 700(27.6) (HSK)	
Max. tool weight		kg(lb)	25 (55.1) (40 / 60 tools), 30(66.1) (90 - 376 tools)				
Tool change time (tool to tool, tools weighing less than 12kg(26.5lb))		s	2				
Tool change time (chip-to-chip, tools weighing less than 12kg(26.5lb))		s	5	5.4	6.2		
Motor	Spindle motor power		kW(Hp)	45 / 25 {37/22, 37/30} {60.3 / 33.5}{49.6 / 29.5, 49.6 / 40.2}*			
Power Source	Power consumption		kVA	79	76	112	
	Compressed air pressure		Mpa	0.54			
Tank Capacity	Coolant tank capacity		L	825	925		
	Lubricant tank capacity		L	7.2			
Machine Dimensions	Height		mm(inch)	3330 (131.1)	3495 (137.6)	3803 (149.7)	
	Length		mm(inch)	5940 (233.9)	6520 (256.7)	7878 (310.2)	
	Width		mm(inch)	3670 (144.5)	3930 (154.7)	4375 (172.2)	
	Weight		kg(lb)	17000 (37478.0)	18000 (39682.6)	27000 (59523.9)	

**FANUC
31i**

Item	Spec.	FANUC 31i
AXES CONTROL		
Controlled axes	4 (X,Y,Z,B)	X, Y, Z, B
Additional controlled axes	ADD 1 AXIS (5TH AXIS)	○
Simultaneously controlled axes	Positioning(G00)/Linear interpolation(G01) : 3 axes Circular interpolation (G02, G03) : 2 axes	●
Least command increment	0.001 mm / 0.0001"	●
Least input increment	0.001 mm / 0.0001"	●
Increment system C	IS-C	○
Interpolation type pitch error compensation		○
Position switch		○
Inverse time feed		○
Cylindrical interpolation	G07.1	○
NURBS interpolation		○
Bell-type acceleration/deceleration before look ahead interpolation	Included in AI contour control I or II (0i-MF, 31/32i)	●
Rigid tapping bell-shaped acceleration/deceleration	Rigid tapping is required.	●
Exponential interpolation		○
Involute interpolation		○
Smooth backlash compensation		●
Automatic corner override	G62	○
Automatic corner deceleration	Included in AI contour control I or II (0i-MF, 31/32i)	●
Cutting feedrate clamp		●
Rapid traverse bell-shaped acceleration/deceleration		●
Handle interruption		○
Manual handle retrace		○
Manual handle feed 2/3 unit		○
Nano smoothing		○
AICC II	200BLOCK	●
AICC II	400 BLOCK	○
High-speed processing	600 BLOCK	○
Look-ahead blocks expansion	1000 BLOCK	○
Linear ACC/DEC before cutting feed interpolation		●
SPINDLE & M-CODE FUNCTION		
M-code function	M 3 digits	●
Spindle orientation		●
Retraction for rigid tapping		●
Rigid tapping	G84, G74	●
TOOL FUNCTION		
Number of tool offsets	200-pairs	●
Number of tool offsets	400-pairs	○
Number of tool offsets	499 / 999 / 2000 -pairs	○
Tool nose radius compensation	G40, G41, G42	●
Tool length compensation	G43, G44, G49	●
Tool life management		●
Addition of tool pairs for tool life management		○
Tool number command	T3 digits	●
Tool offset memory C	Geometry / Wear and Length / Radius offset memory	●
Tool length measurement		●
Tool length offset		●
Tool offset	G45 - G48	○
Rotary table dynamic fixture offset		○
Work setting error compensation		○
PROGRAMMING & EDITING FUNCTION		
Absolute / Incremental programming	G90 / G91	●
Automatic Coordinate system setting		●
Background editing		●
Canned cycle	G73, G74, G76, G80 - G89, G99	●
Circular interpolation by radius programming		●
Custom macro		●
Addition of custom macro common variables	#100 - #199, #500 - #999	●
Macro executor		●
Custom software	2MB	-
Custom software	4MB, 6MB	-
Custom software	8MB	●
Custom software	12MB, 16MB	○

Item	Spec.	FANUC 31i
Decimal point input		●
Extended P-code variables 256Kbyte		-
Extended P-code variables 512Kbyte		●
Extended P-code variables 1Mbyte		-
Extended part program editing		●
Part program storage	256KB(640m)	●
Part program storage	512KB(1,280m)	○
Part program storage	1MB(2,560m)	○
Part program storage	2MB(5,120m)	○
Part program storage	4MB(1,0240m)	○
Part program storage	8MB(2,0480m)	○
Inch/metric conversion	G20 / G21	●
Label skip		●
Maximum commandable value	±99999.999mm (±9999.9999 inch)	●
Number of Registered programs	400 ea	-
Number of Registered programs	500 ea	●
Optional block skip	1 BLOCK	●
Optional block skip	9 BLOCK	○
Optional stop	M01	●
Program file name	32 characters	●
Program number	O4-digits	-
Sequence number	N 8-digit	N8 digit
Playback function		○
Workpiece coordinate system	G52 - G59	●
Addition of workpiece coordinate system	G54.1 P1 - 48 (48 pairs)	●
Addition of workpiece coordinate system	G54.1 P1 - 300 (300 pairs)	○
Tilted working plane indexing command	G68.2	○
OTHERS FUNCTIONS (Operation, setting & Display, etc)		
Embedded Ethernet		●
MDI / DISPLAY unit	8.4" Color LCD, keyboard for data input(small), soft-keys	-
MDI / DISPLAY unit	10.4" Color LCD, Keyboard for data input, soft-keys	●
MDI / DISPLAY unit	15" Color LCD, Keyboard for data input, soft-keys	○
I/O interface	RS - 232C	●
USB memory interface	Only Data Read & Write	●
Stored stroke check 2		○
Multi language display		●
3rd / 4th reference return		○
Cs contouring control		○
Reader/Puncher interface (for 2ch)		●
Multi spindle control		-
Retraction for 3-dimensional rigid tapping		○
Extended Spindle orientation (Spindle Multi Orientation)		●
Chopping function	G81.1	○
High speed skip function		○
Polar coordinate command	G15 / G16	○
Polar coordinate interpolation	G12.1 / G13.1	○
Programmable mirror image	G50.1 / G51.1	○
Scaling	G50, G51	○
Single direction positioning	G60	○
Pattern data input		○
Jerk control	AI contour control II is required.	○
Fast Data server with 1GB PCMCIA card		○
Fast Ethernet		○
3-dimensional coordinate conversion		○
3-dimensional tool compensation		○
3-dimensional manual feed		○
Tape format for FS15		○
Tape format for FS10/11		-
Figure copying	G72.1, G72.2	○
Machining time stamp function		○
Machining quality level adjustment		○
EZ Guide I with 10.4" Color TFT	- Doosan infracore Conversational Programming Solution - When the EZ Guide i is used, the Dynamic graphic display cannot application	○
Dynamic graphic display (with 10.4" Color TFT LCD)	- Machining profile drawing. - When the EZ Guide i is used, the Dynamic graphic display cannot application	○

Responding to Customers Anytime, Anywhere

Basic information

Basic Structure
Cutting
Performance

Machine
Information

Standard/Optional
Specifications
Applications
Diagrams
Machine & NC Unit
Specifications

Customer Support

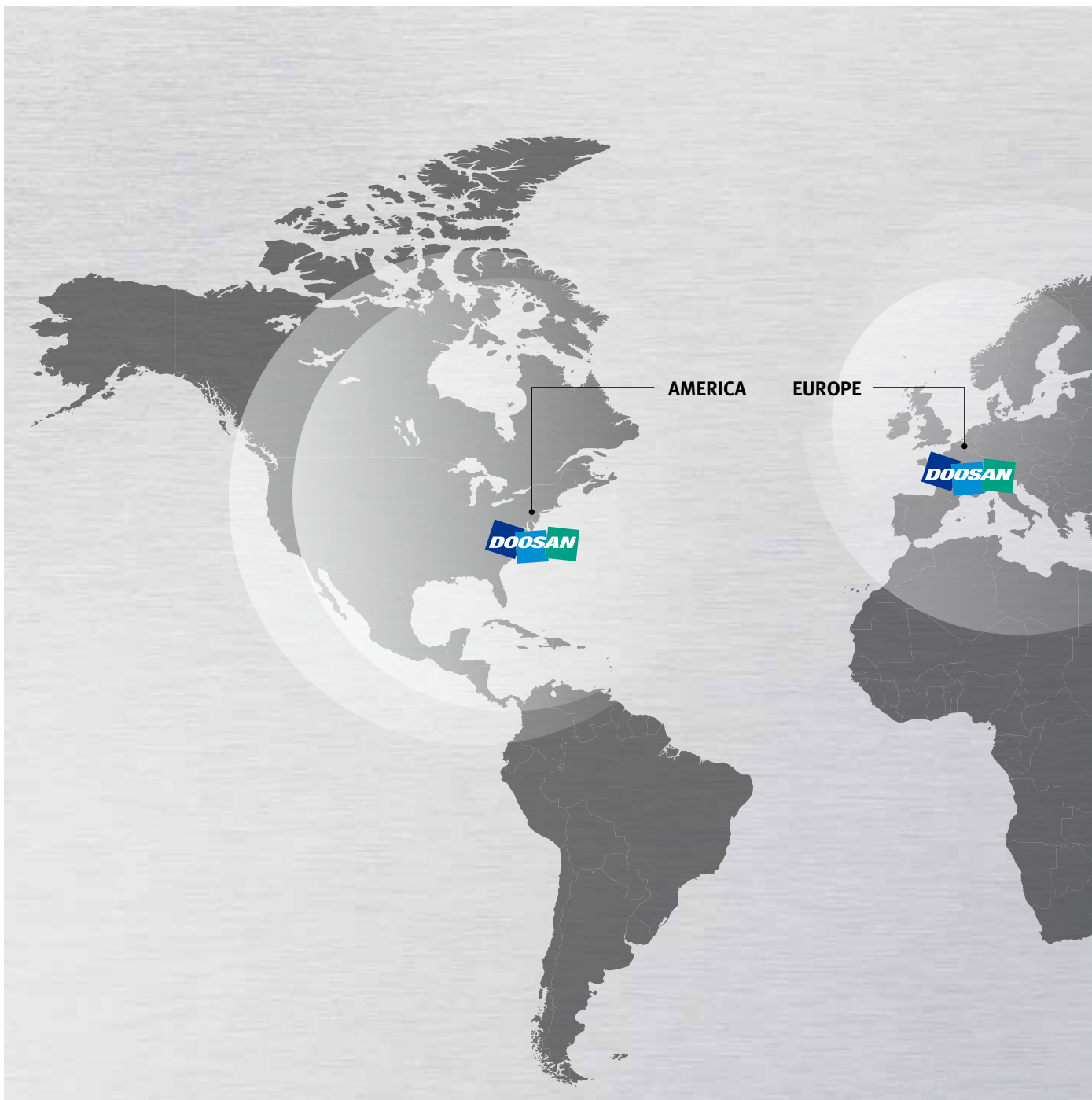

Global Service Support Network

Corporations

5

Dealer Networks

122

Technical Centers

18

Factories

3

Technical Center: Sales Support, Service Support, Parts Support

Doosan Machine Tools' Global Network, Responding to Customer's Needs nearby, Anytime, Anywhere

Doosan machine tools provides a system-based professional support service before and after the machine tool sale by responding quickly and efficiently to customers' demands.

By supplying spare parts, product training, field service and technical support, we can provide top class support to our customers around the world.



Domestic Service Support Network

Integrated Support Centers

2

Sales Branch Offices

7

Post-Sales Service Centers

6

Designated Repair Service Centers

31

Customer Support Service

We help customers to achieve success by providing a variety of professional services from pre-sales consultancy to post-sales support.

Supplying Parts



- Supplying a wide range of original Doosan spare parts
- Parts repair service

Field Services



- On site service
- Machine installation and testing
- Scheduled preventive maintenance
- Machine repair

Technical Support



- Supports machining methods and technology
- Responds to technical queries
- Provides technical consultancy

Training



- Programming / machine setup and operation
- Electrical and mechanical maintenance
- Applications engineering

Main Specifications

NHP series

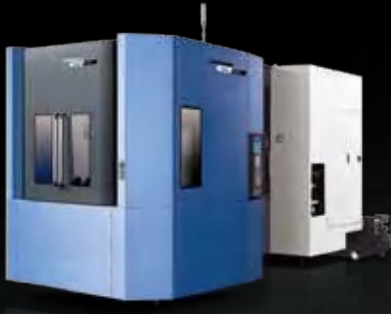

Description	Unit	NHP 5500	NHP 6300	NHP 8000
Max. spindle speed	r/min	10000	10000	10000
Max. spindle motor power	kW(Hp)	45(60.3)	45(60.3)	45(60.3)
Pallet size	mm(inch)	500 x 500 (19.7 x 19.7)	630 x 630 (24.8 x 24.8)	800 x 800 (31.5 x 31.5)
Tool taper	taper	50	50	50
Travel distance (X / Y / Z)	mm(inch)	800 / 750 / 850 (31.5 / 29.5 / 33.5)	1050 / 900 / 1000 (41.3 / 35.4 / 39.4)	1400 / 1200 / 137 (55.1 / 47.2 / 53.9)
Tool storage capacity	ea	40	40	40
NC system	-	FANUC / SIEMENS	FANUC / SIEMENS	FANUC / SIEMENS



Doosan Machine Tools

<http://www.doosanmachinetools.com>

www.facebook.com/doosanmachinetools

Optimal Solutions for the Future

Head Office

Yeonkang Bldg., 6th FL., 270, Yeonji-dong,
Jongno-gu, Seoul, Korea
Tel +82-2-3670-5345 / 5362
Fax +82-2-3670-5382

Doosan Machine Tools America

19A Chapin Rd., Pine Brook, NJ 07058, U.S.A.
Tel +1-973-618-2500
Fax +1-973-618-2501

Doosan Machine Tools China

Room 101,201,301, Building 39 Xinzhuang Highway
No.258 Songjiang District,China Shanghai(201612)
Tel +86 21-5445-1155
Fax +86 21-6405-1472

Doosan Machine Tools Europe

Emdener Strasse 24, D-41540 Dormagen, Germany
Tel +49-2133-5067-100
Fax +49-2133-5067-111

Doosan Machine Tools Japan

#2412, Mita Kokusai Bldg. 1-4-28 Mita,
Minato-ku, Tokyo 108-0073, Japan
Tel +81 3 5730 9013
Fax +81 3 5730 9016

Doosan Machine Tools India

106 / 10-11-12, Amruthahalli, Byatarayanapura,
Bellary road, Bangalore-560 092, India
Tel +91-80-4266-0122 / 121 / 100



* For more details, please contact Doosan Machine Tools.

* The specifications and information above-mentioned may be changed without prior notice.

* Doosan Machine Tools Co., Ltd. is a subsidiary of MBK Partners. The trademark  DOOSAN is used under a licensing agreement with Doosan Corporation, the registered trademark holder.