



Optimal Solutions for the Future

DBD series



**DBD Series
for large sized
work-piece**

DBD series

DBD 1270
DBD 1580

ver. EN 160823 SU

DBD Series For Large Sized Work-Piece

DBD series

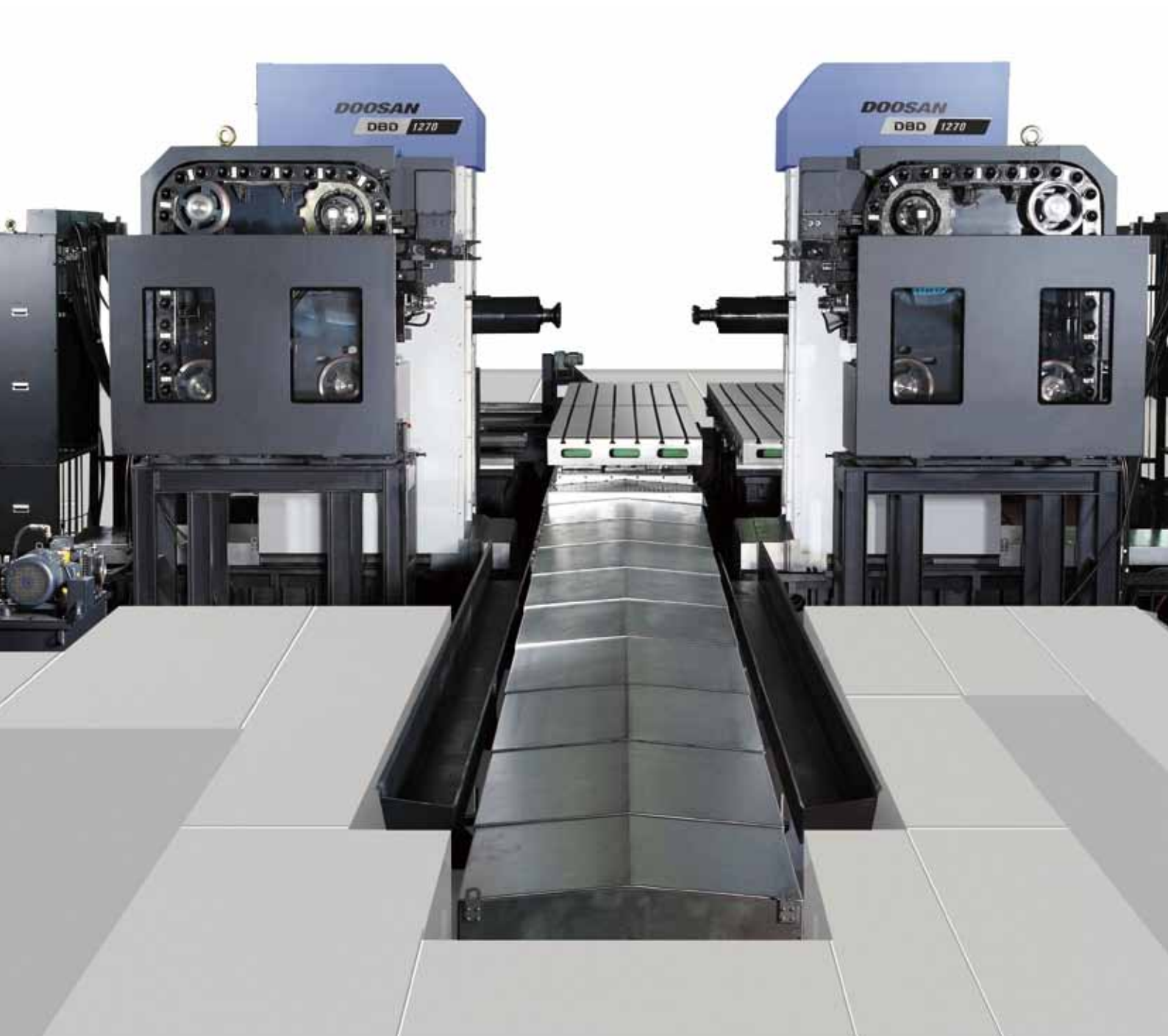

- Concentric machining through duplex spindle
- Big table for long and symmetrical machining
- Wide work area through axes extension



Structure

Table

Table moving type realized by Linear Motion Guide provides fast rapid traverse.

DBD 1270 : 1250 x 7000 mm
DBD 1580 : 1500 x 8000 mm



Spindle Head

Spindle driving torque optimized by 3-steps gear change mechanism

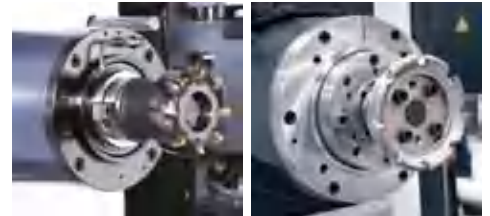

DBD 1270

DBD 1580

Automatic Pallet Changer

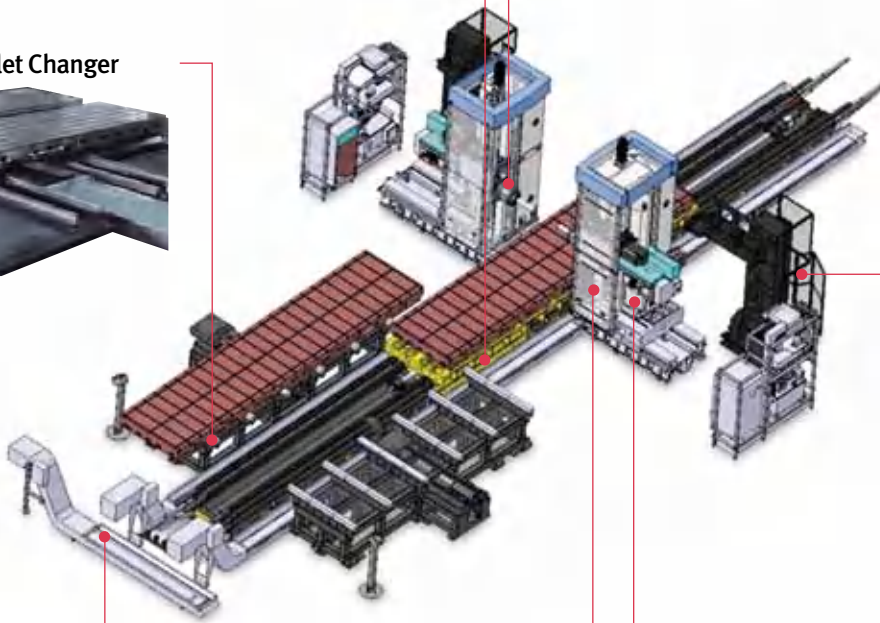

Automatic Tool Changer opt.

High reliability, reducing noise
Tool : 40/60



Column

DBD 12 series

DBD 15 series

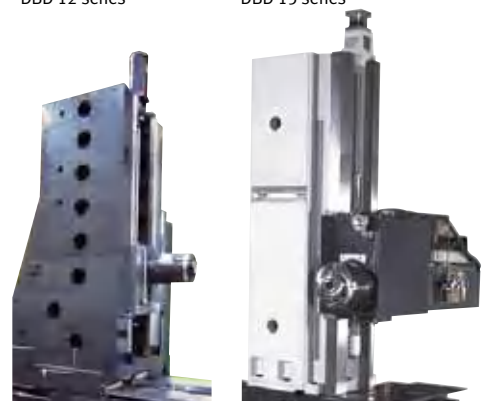

Hinged Chip Conveyor opt.



Improved Operating Convenience

Membrane type main OP panel



Spindle



DBD 1270

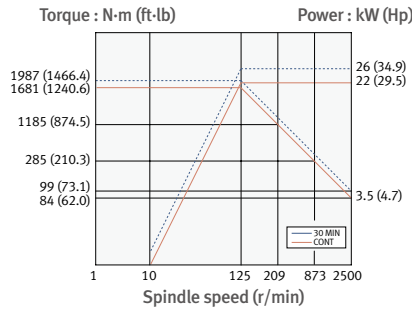

DBD 1580

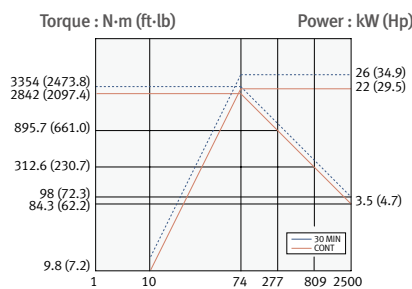

Max. spindle speed **2500 r/min** Gear Transmission **3 steps**
 Motor (Cont. / 30 min) **26/22 kW (34.9 / 29.5 Hp)**

Torque range may differ by each model among DBD series.
 For further information and more details, contact DOOSAN.

Comparison of spindle head

DBD 12 series

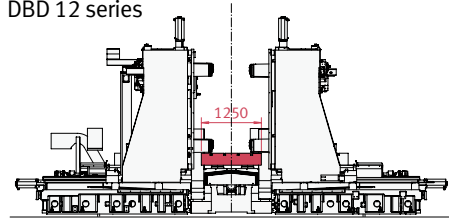

DBD 15 series

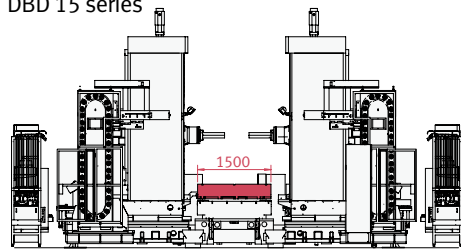

	Unit	DBD 12 series (Z-axis spindle)	DBD 15 series (Z/W-axis spindle)
Table size (Width)	mm (inch)	1250 (49.2)	1500 (59.1)
Column ~ Table center	mm (inch)	800 (31.5)	1040 (40.9)
Spindle nose	mm (inch)	550 (21.7)	340 (13.4)
The distance between spindle	mm (inch)	500 (19.7)	400 (15.7)
W-axis travel	mm (inch)	-	500 (19.7)
Spindle bearing inner dia.	mm (inch)	ø100 (3.9)	ø190 (7.5)
Spindle nose dia.	mm (inch)	ø320 (12.6)	ø390 (15.4)

Table *

Table size [Width x Length]

DBD 1270	DBD 1580
1250 × 7000 mm (49.2 x 275.6 inch)	1500 × 8000 mm (59.1 x 315.0 inch)

* Please consult with Doosan for increasing the table length.

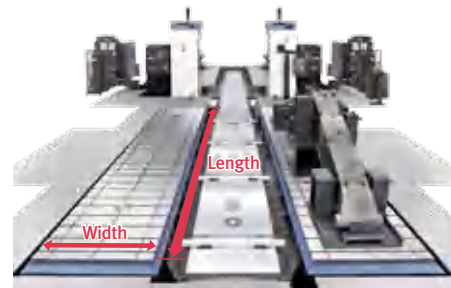

Automatic Tool Changer

Tool Magazine by servo control will be accomplished higher reliability, speed smooth operation and reducing noise.



Acceptable Tool Dimensions

	Spec.	Shape
Max. Tool Diameter	Facing Tool D = ø130mm (ø5.1 inch) [Continuous]	
	Boring Tool D = ø400 mm (15.7 inch) [Adjacent pots empty]	
Max. Tool Length	L = 400 mm (15.7 inch)	
Max. Tool Weight	W = 25 kg (55.1 lb)	

Allowable moment : 34 N-m (25.1 ft-lb)
 * Please attention to cutting edge direction and tool shape in case of Max. Boring tool

Machine Specifications

Description		Unit	DBD 1270	DBD 1580	
Travels	Travel distance	X-axis	mm (inch)	7000 (275.6)	8000
		Y-axis	mm (inch)	1500 (59.1)	2000
		Z-axis	mm (inch)	1000 (39.4)	450
		W-axis	mm (inch)	-	500
	Spindle center to table top	mm (inch)	150~1650 {150~2150} (5.9~64.9 {5.9~84.6})	0~2000	
Distance between spindles		mm (inch)	500~2500 (19.7~98.4)	400~2300	
Feedrates	Rapid Traverse Rate	X-axis	mm/min (ipm)	12000 (472.4)	10000
		Y-axis	mm/min (ipm)	12000 (472.4)	10000
		Z-axis	mm/min (ipm)	12000 (472.4)	6000
	Cutting feedrate	X / Y / Z-axis	mm/min (ipm)	4000 (157.5)	
Table *	Table size		mm (inch)	1250 × 7000 (49.2 × 275.6)	1500 × 8000 (59.1 × 315.0)
	Table loading capacity		kg (lb)	7000 (15432.1)	
Spindle	Max. spindle speed		r/min	2500	
	Number of speed range			3	
	Spindle Taper		-	ISO #50, 7/24 taper	
	Spindle motor (30min./cont.)		kW (Hp)	26 / 22 (34.9 / 29.5)	
	Tool Shank		-	MAS 403 BT50	
Automatic Tool Changer 	Pull stud		-	MAS 403 P50T-1 (45°)	
	Tool storage capa.		ea	40 {60}	
	Max. tool diameter	Continous	mm (inch)	130 (5.1)	
		1 pot empty	mm (inch)	250 (9.8)	
	Max. tool length		mm (inch)	400 (15.7)	
	Max. tool weight		kg (lb)	25 (55.1)	
	Method of tool selection			Fixed address	
Machine Dimensions	Length x Width		mm (inch)	20800 × 10700 (818.9 × 421.3)	23000 × 10700 (905.5 × 421.3)
	Height		mm (inch)	4500 (177.2)	5000 (196.9)
	Weight		kg (lb)	58000 (127866.2)	86000 (189594.7)

* Please consult with your Doosan for Increasing the table length.

{ } : Option

Standard Feature

- APC (Side shuttle : Two pallet)
- Assembly & Operations tools
- Foot switch for tool clamp
- Leveling blocks and Anchoring bolts
- Manual
- Mono lever Jog
- Operator call lamp (red, yellow, green)
- Portable MPG & Operation Box
- Spindle internal cooling device
- Spindle Load Meter
- Spindle oil cooling unit
- Spindle orientation
- T-SLOT
- Work light

Optional Feature

- Air conditioner
- Air gun
- Auto measuring system (RMP60)
- Automatic tool changer
- Auto workpiec offset function + RMP60
- BIG PLUS spindle
- Chip air blow
- Chip conveyor
- Chip bucket
- Linear scale (X,Y1,Y2)
- Noise filter
- Pallet expansion

• The specifications and information above-mentioned may be changed without prior notice.
• For more details, please contact Doosan.

NC Unit Specifications

Fanuc 32i

AXES CONTROL

- Controlled axes	5 axes
- Simultaneous controlled axes	Positioning(G00)/Linear interpolation (G01) : 3 axes Circular interpolation (G02, G03) : 2 axes
- Backlash compensation	
- Emergency stop / overtravel	
- Follow up	
- Least command increment	0.001mm / 0.0001(inch)
- Least input increment	0.001mm / 0.0001(inch)
- Machine lock	all axes / Z axis
- Stored pitch error compensation	Pitch error offset compensation for each axis
- Stored stroke check 1	Overtravel controlled by software

INTERPOLATION & FEED FUNCTION

- 2nd reference point return	G30
- Circular interpolation	G02, G03
- Dwell	G04
- Feed per minute	mm / min
- Feedrate override (10% increments)	0 - 200 %
- Jog override (10% increments)	0 - 200 %
- Linear interpolation	G01
- Manual handle feedrate	0.1/0.01/0.001mm
- Override cancel	M48 / M49
- Positioning	G00
- Rapid traverse override	F0 (fine feed), 25 / 50 / 100 %
- Reference point return	G27, G28, G29
- Skip function	G31
- Helical interpolation	
- NANO AICC (AI Contour Control)	80 block preview
- Thread cutting, synchronous cutting	
- Program restart	
- Automatic corner deceleration	
- Feedrate clamp by circular radius	
- Linear ACC/DEC before interpolation	

SPINDLE & M-CODE FUNCTION

- M- code function	M 3 digits
- Spindle orientation	
- Spindle serial output	
- Spindle speed command	S5 digits
- Spindle speed override (10% increments)	10 - 150 %
- Rigid tapping	G84, G74

TOOL FUNCTION

- Cutter compensation C	G40, G41, G42
- Number of tool offsets	200 ea
- Tool length compensation	G43, G44, G49
- Tool number command	T3 digits
- Tool life management	Geometry / Wear and Length / Radius offset memory
- Tool offset memory C	

PROGRAMMING & EDITING FUNCTION

- Auto. Coordinate system setting	
- Background editing	
- Canned cycle	G73, G74, G76, G80 - G89, G99
- Circular interpolation by radius programming	
- Custom macro B	
- Custom size	512kb

- I / O interface	RS - 232C
- Inch / metric conversion	G20 / G21
- Local / Machine coordinate system	G52 / G53
- Maximum commandable value	±99999.999mm (±9999.9999 inch)
- No. of Registered programs	500 ea
- Optional block skip	
- Optional stop	M01
- Part program storage	640 m
- Program number	O4-digits
- Program protect	
- Program stop / end	M00 / M02,M30
- Programmable data input	Tool offset and work offset are entered by G10, G11
- Sub program	Up to 4 nesting
- Tape code ISO / EIA Automatic discrimination	
- Work coordinate system	G54 - G59
- Additional work coordinate system (48 Pair)	G54.1 P1 - 48 pairs
- Coordinate system rotation	G68, G69
- Macro executor	

Others Function (Operation, Setting & Display, etc)

- Alarm history display	
- Cycle start / Feed hold	
- Display of PMC alarm message	Message display when PMC alarm occurred
- Dry run	
- Ethernet function (Embedded)	
- Graphic display	Tool path drawing
- Help function	
- Loadmeter display	
- MDI / DISPLAY unit	10.4" color LCD, Keyboard for data input, soft-keys
- Memory card interface	
- Operation functions	Tape / Memory / MDI / Manual
- Program restart	
- Search function	Sequence NO. / Program NO.
- Servo setting screen	
- External data input	
- Multi language display	

OPTIONAL SPECIFICATIONS

- 3rd / 4th reference return	
- Addition of tool pairs for tool life management	1024 pairs
- Additional controlled axes	max. 6 axes in total
- Automatic corner override	G62
- Chopping function	G81.1
- Cylindrical interpolation	G07.1
- Interpolation type pitch error compensation	
- EZ Guide i (Doosan infracore Conversational Programming Solution) with 10.4" Color TFT	
- Increment system 1/10	
- Manual handle feed 2/3 unit	
- Handle interruption	
- High speed skip function	
- No. of Registered programs	1000 ea
- Number of tool offsets	400 ea
- Optional block skip addition	9 blocks
- Part program storage	1280 / 2560 / 5120 m
- Polar coordinate command	G15 / G16
- Polar coordinate interpolation	G12.1 / G13.1
- Programmable mirror image	G50.1 / G51.1
- Scaling	G50, G51
- Stored stroke check 2 / 3	
- Tool offset	G45 - G48
- Position switch	
- Data server	
- Fast ethernet	



Doosan Machine Tools

<http://www.doosanmachinetools.com>

www.facebook.com/doosanmachinetools

Optimal Solutions for the Future

Head Office

Yeonkang Bldg., 6th FL., 270, Yeonji-dong,
Jongno-gu, Seoul, Korea
Tel +82-2-3670-5345 / 5362
Fax +82-2-3670-5382

Doosan Machine Tools America

19A Chapin Rd., Pine Brook, NJ 07058, U.S.A.
Tel +1-973-618-2500
Fax +1-973-618-2501

Doosan Machine Tools China

Room 101,201,301, Building 39 Xinzhuang Highway
No.258 Songjiang District, China Shanghai(201612)
Tel +86 21-5445-1155
Fax +86 21-6405-1472

Doosan Machine Tools Europe

Emdener Strasse 24, D-41540 Dormagen, Germany
Tel +49-2133-5067-100
Fax +49-2133-5067-111

Doosan Machine Tools Japan

#2412, Mita Kokusai Bldg. 1-4-28 Mita,
Minato-ku, Tokyo 108-0073, Japan
Tel +81 3 5730 9013
Fax +81 3 5730 9016

Doosan Machine Tools India

106 / 10-11-12, Amruthahalli, Byatarayanapura,
Bellary road, Bangalore-560 092, India
Tel +91-80-4266-0122 / 121 / 100



* For more details, please contact Doosan Machine Tools.

* The specifications and information above-mentioned may be changed without prior notice.

* Doosan Machine Tools Co., Ltd. is a subsidiary of MBK Partners. The trademark  **DOOSAN** is used under a licensing agreement with Doosan Corporation, the registered trademark holder.