



*Optimal Solutions for the Future*

# PUMA TT2500 series



---

**Multi-Axis  
Turning Center**

---

**PUMA TT2500 series**

PUMA TT2500S  
PUMA TT2500MS  
PUMA TT2500SY

---

ver. EN 160715 SU

**Multi-axis turning center combines  
Y-axis function, two spindles and  
upper & lower turret in a machine**

**PUMA TT 2500 series**



High performance turning center featuring first & second spindle that have the same power and capacity, with upper & lower turrets on the grounded box type bed. Simultaneous machining on two faces with both spindles and turrets and virtual realization of Y-axis function will bring you double productivity.

■ PUMA TT2500 Series

Model	Left spindle (C1)	Right spindle A (C2)	Upper turret X1, Z1, (Y)	Lower turret X2, Z2	Number of axis
PUMA TT2500S	●	●	●	●	5-axis
PUMA TT2500MS	● [+C1]	● [+C2]	● (+M)	● (+M)	7-axis
PUMA TT2500SY	● [+C1]	● [+C2]	● (+M, Y)	● (+M)	8-axis



## Main Spindle

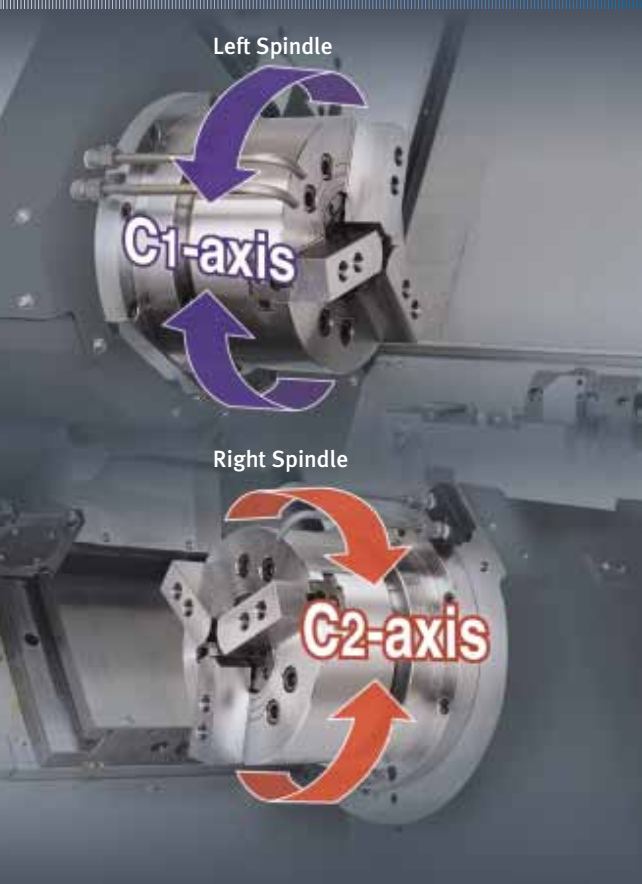

## PUMA TT 2500S/MS/SY

Max. spindle speed

**3500 r/mim**

Motor (30 min)

**26 / 22 kW**  
(34.9 / 29.5 Hp)

Perfect integral motor driven spindles.

Both Left and Right spindle are designed to minimize maleffects of thermal distortion which can hit continuous machining precision seriously. Especially the same capacity of both spindles improves productivity remarkably of single machine.

### Oil Cooling Unit for Spindles

Both left and right spindle have built-in motor spindles that wholly covered with oil cooling system to ensure remarkable range of applications from heavy duty cutting with high power at low speed to fine to finish cutting at high speed and optimize thermal displacement.

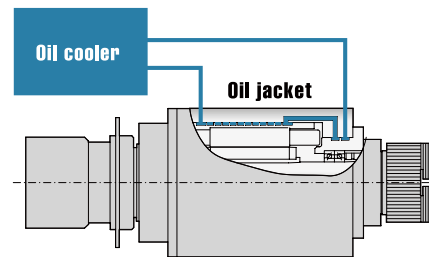

## Turret

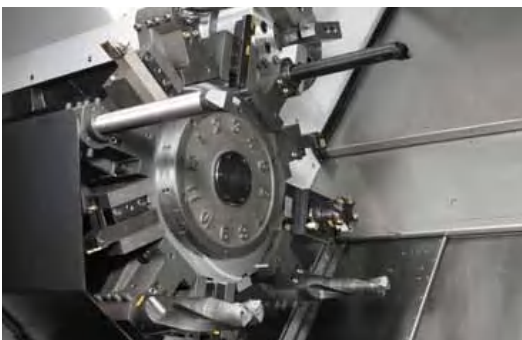

### Radial BMT65P

The turret features BMT65P style tooling in which the toolholders are mounted directly to the turret's periphery using 4 large bolts.

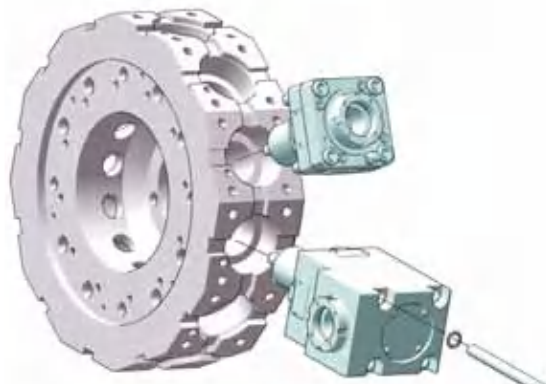

Index time  
(1-station swivel)

**0.20 s**

No. of tool station  
(Upper+Lower turret)

**24** (12+12)  
**st**

Total of 24 tool stations upper and lower turret(BMT65P) make it possible to complete complicated parts requiring many tools in just one set-up. Reliable servo driven turrets reduce the total cycle time required to machine parts.

# Rapid Traverse

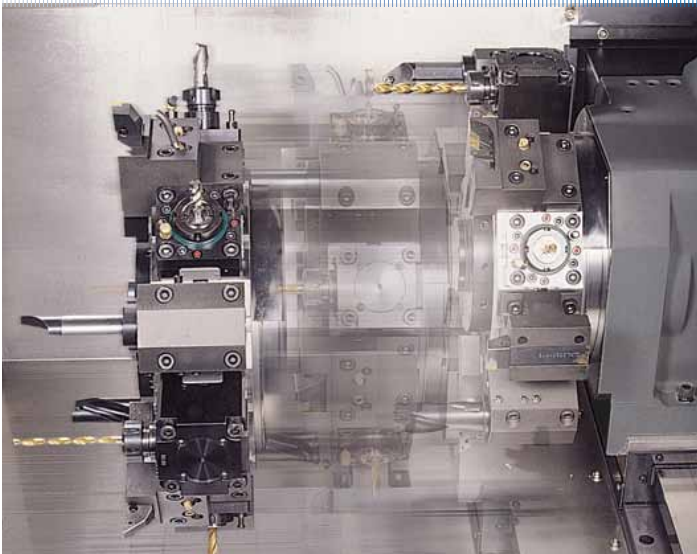

X-axis

**20 m/min**  
(787.4 ipm)

Z-axis

**24 m/min**  
(944.9 ipm)



- Outstanding rigidity for high feedrates

# Virtual y-Axis Function

Y-axis addition to upper turret on SY series brings complex machining to completion in just one set-up. Synchronous interpolation of X1-axis and Ys-axis in double ways structure creates the Y-axis function.

Y-axis travel

**120 mm** ( $\pm 60\text{mm}$ )  
(4.7 ( $\pm 2.4$ ) inch)

Y-axis rapid

**7.5 m/min**  
(295.3 ipm)

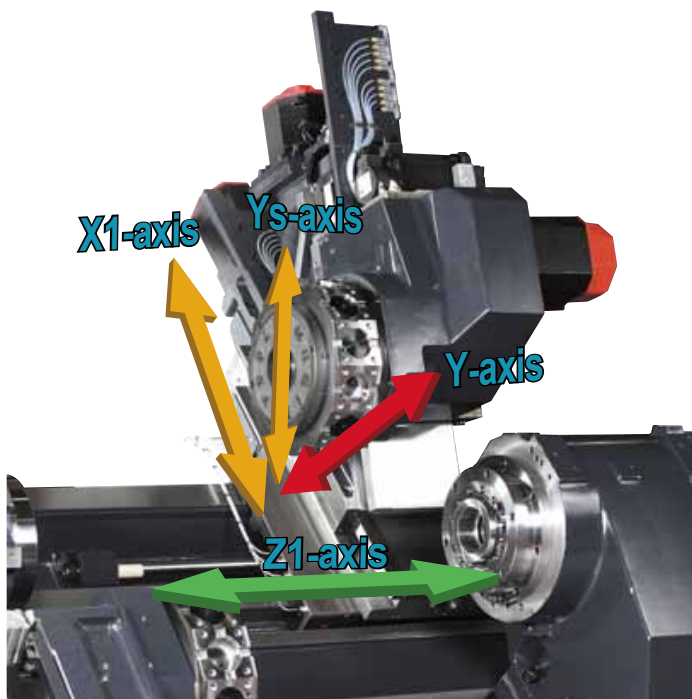

## Y-axis Working Range

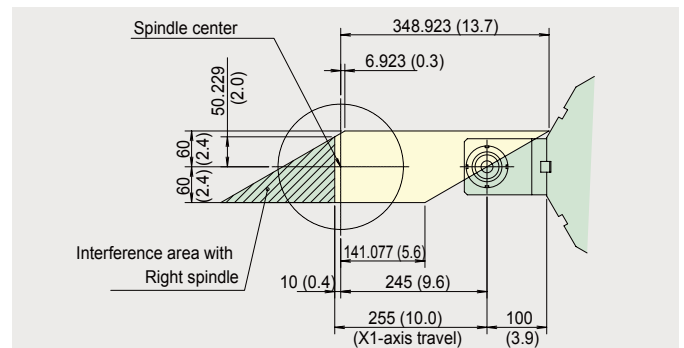

Angular Milling unit moving area

## Y-axis Working Range

By simultaneous X-Y-Z-axis feed control and C-axis function to guide precise circular orientation of spindle, Y/X axes circular interpolation simplifies the machining of complex shapes in faster cycle time.



On-center face groove

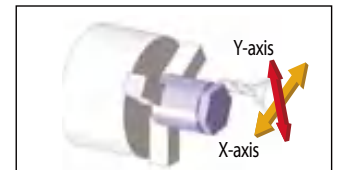

Poly-side machine



Off-center side groove



Y&X-axis circular interpolation

# Axis Features

## Travel

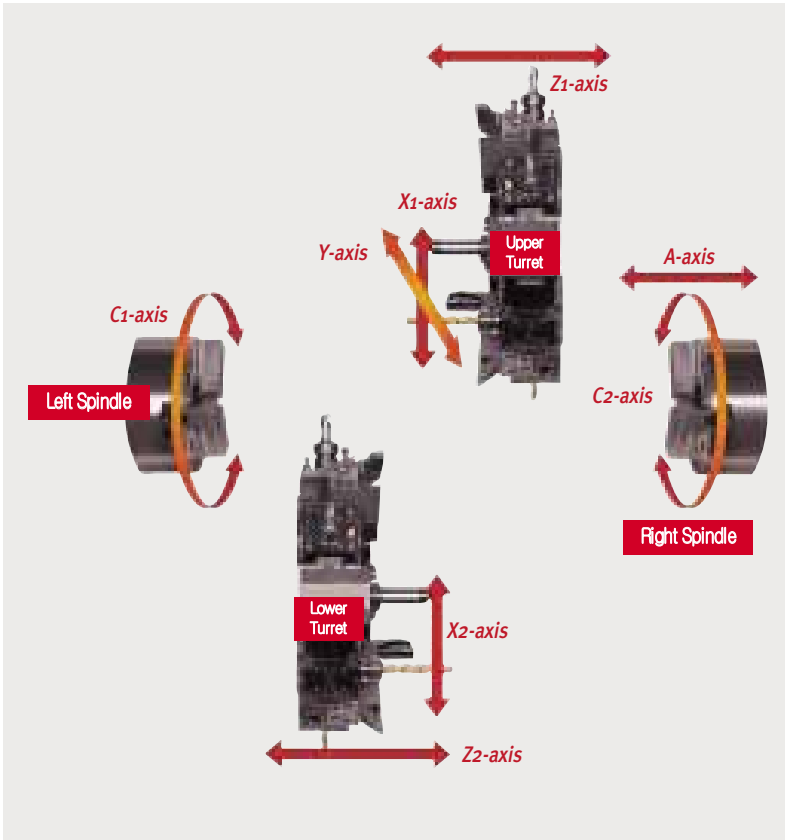

X1-axis (Upper turret)

**255 mm**  
(10.0 inch)

X2-axis (Lower turret)

**190 mm**  
(7.5 inch)

Z1-axis (Upper turret)

**800 mm**  
(31.5 inch)

Z2-axis (Lower turret)

**900 mm**  
(35.4 inch)

A-axis

**810 mm**  
(31.9 inch)

## Machining range

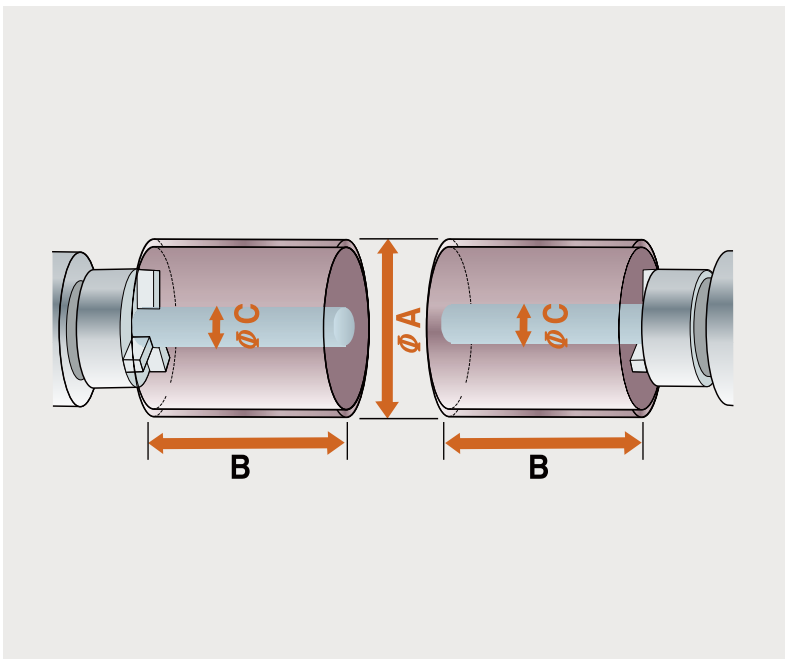

A : Max. turning dia.

on Upper turret

**390 mm**  
(15.4 inch)

on Lower turret

**300 mm**  
(11.8 inch)

B : Max. turning length

**350 mm** (13.8 inch)

C : Max. bar working dia.

**76 mm** (3.0 inch)

# Machine Construction

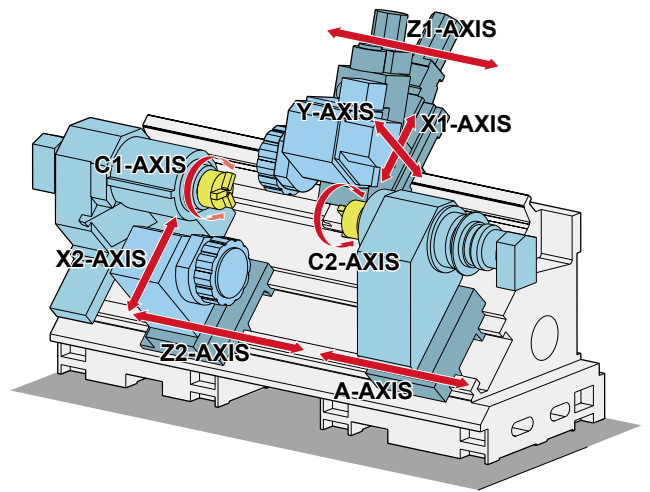
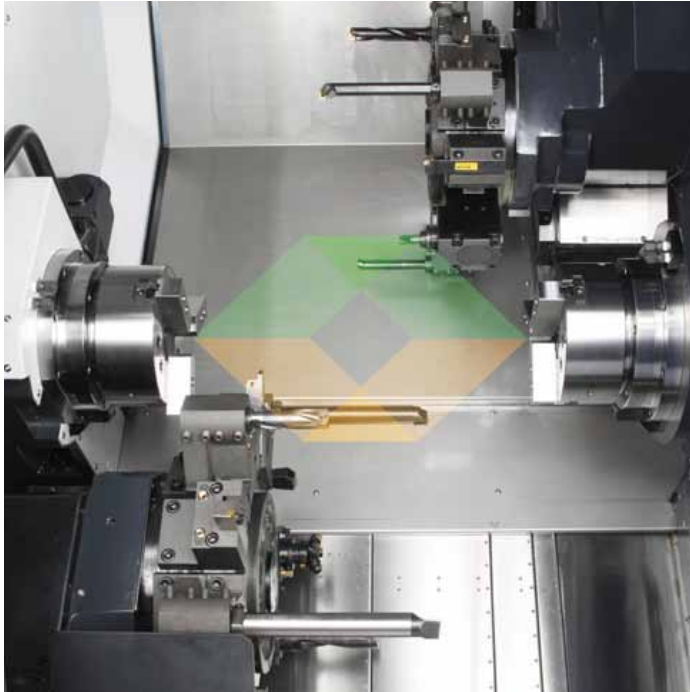

Continuous process accuracy,  
Shorten setting time,  
Optimal distribution of cycle and  
Automated works

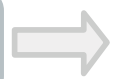

Achievement of  
PUMA TT machines

Perfect integration of multi-process and high productivity are achieved by Left & right spindle of the same power and capacity, with upper & lower turrets on the grounded box type bed.

# Robust Design



All guide ways are wide wraparound rectangular type for unsurpassed long term rigidity and accuracy



FEM (Finite Element Method) Analysis

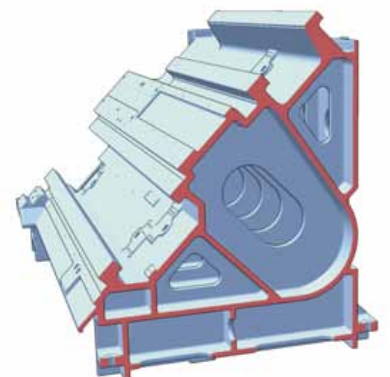

The heavily ribbed torque tube design prevents twisting and deformation.

# Ergonomic Design

## Safety & Operability

### ● Safety window on front door

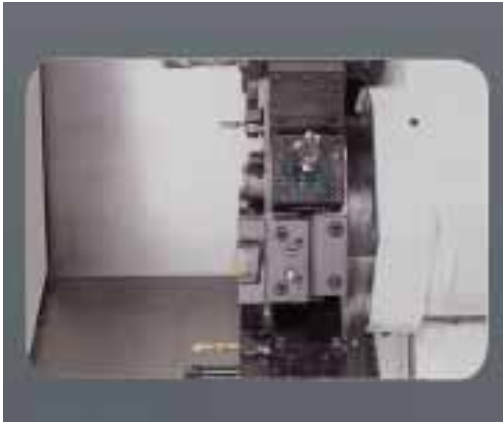

Viewing window is designed and was tested under heavy condition to protect operator against possible dangers during real cutting thanks to its shock absorbing laminated glass and double panel construction. The window without grating also provides a clear view of the machine inside.

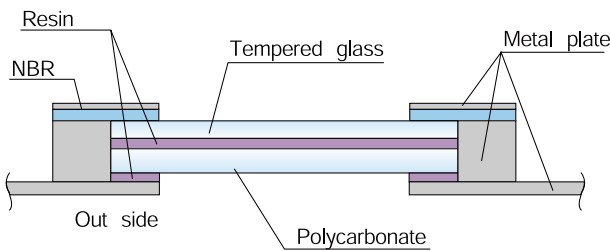

### ● Swivel type operator panel

Operator oriented design with 90° swivel



### ● High maintainability

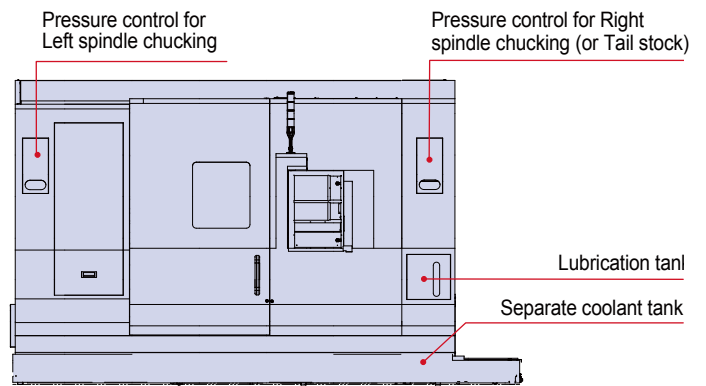

# Eco-Friendly Design



## Oil Skimmer (opt.)

Another suggestion to prolong the life time of the coolant water. A belt-driven type oil skimmer picks up and removes waste oil from the coolant tank that is easily drained.

## Collection of Waste Lubrication Oil

Less waste lubrication oil extends the life time of the coolant water and cut down the grime and offensive smell of the machine inside.

## No Coolant Leakage

Rigorously designed, manufactured and tested machine covers do not permit coolant leakage in any condition. The factory always keeps our environment clean.



# Machine Capacity

## Heavy-Duty Cutting, OD (Left spindle & upper turret)

Making full use of the high output motor, heavy-duty O.D. cutting is powerful and precise even with large workpieces.



Material	Carbon steel, SM45C	Chip removal rate	Cutting depth
Cutting speed (m/min (ipm))	120 (4724.4)	<b>348</b> Cm <sup>3</sup> /min (21.2 inch <sup>3</sup> /min)	<b>10</b> mm (0.4 inch)
Feedrate (mm/rev (ipr))	0.36 (0.0)		
Spindle speed (r/min)	320		

## Balanced Cutting, OD (Left spindle & upper - lower turret)

The synchronous control of Upper and Lower turrets makes O.D. cutting with high precision balanced cutting.

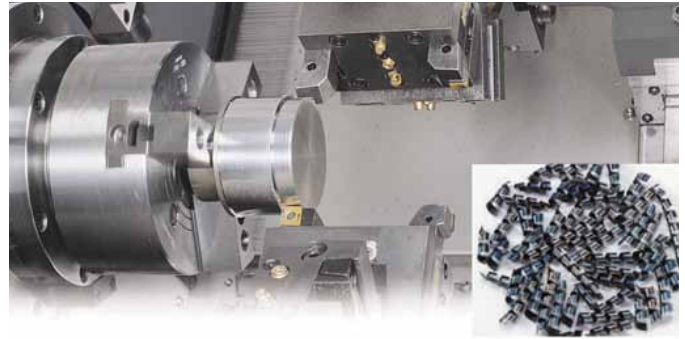

Material	Carbon steel, SM45C	Chip removal rate	Cutting depth
Cutting speed (m/min (ipm))	120 (4724.4)	<b>367</b> Cm <sup>3</sup> /min (22.4 inch <sup>3</sup> /min)	<b>5 mm</b> × <b>2</b> (0.2 inch)
Feedrate (mm/rev (ipr))	0.4		
Spindle speed (r/min)	320		

## Drilling



Tool	∅ 20 HSS drill
Material	Carbon steel SM45C
Rotary tool spindle speed (r/min)	1000
Feedrate (mm/rev (ipr))	0.3 (0.0)
Chip removal rate (cm <sup>3</sup> /min (inch <sup>3</sup> /min))	60 (3.7)
Drilling depth (mm (inch))	10 (0.4)

## Tapping



Tool	M16 × 2.0
Material	SM45C (JIS S45C)
Rotary tool spindle speed (r/min)	600
Feedrate (mm/min (ipm))	1200 (47.2)

## Machining examples



## High productivity

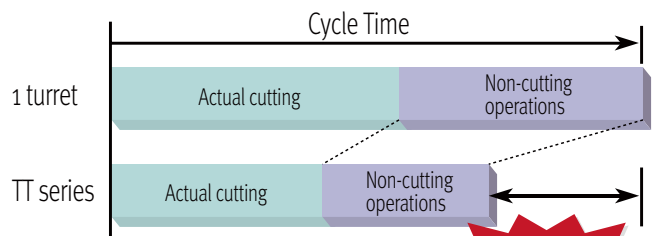

**Productivity X 1.7**

# Reliable Long-Run Machining Accuracy

## Roundness

**0.40** μm

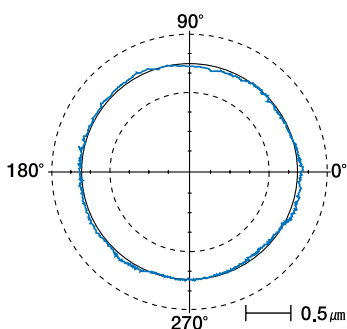

## Roughness

**0.23** μmRa

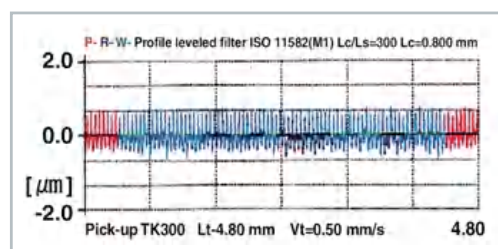

■ The machining accuracy indicated is just for reference. Depending on cutting and environmental conditions during measurement, the results can be different.

Tool	Diamond Tool [nose Ro.8]
Material	AL2024
Outer diameter (mm (inch))	60 (2.4)
Spindle speed (r/min)	1300
Feedrate (mm/rev (ipr))	0.05 (0.0)

# Optional Equipments



Collet chuck

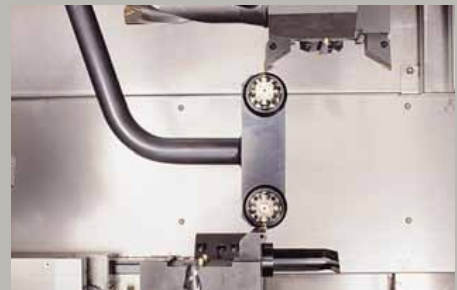

Auto tool pre-setter



Oil skimmer



Coolant blower

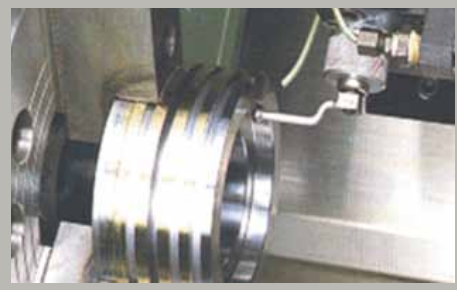

Work measurement



Oil mist collector

# Optimal Support System of Automatic Operation (option)

## Safety & Operability

TT series can be integrated perfectly with a high-speed gantry loader to increase productivity in both short and long production runs.

Max. work diameter	Ø255 mm (Ø10.0 inch)
Max. work length	160 mm (6.3 inch)
Max. work weight	15 kg (33.1 lb)
Max. speed of X-axis	90 m/min (3543.3 ipm)
Max. speed of Z-axis	100 m/min (3937.0 ipm)
Number of pallets	14 stations
Stack height	450 mm (17.7 inch)

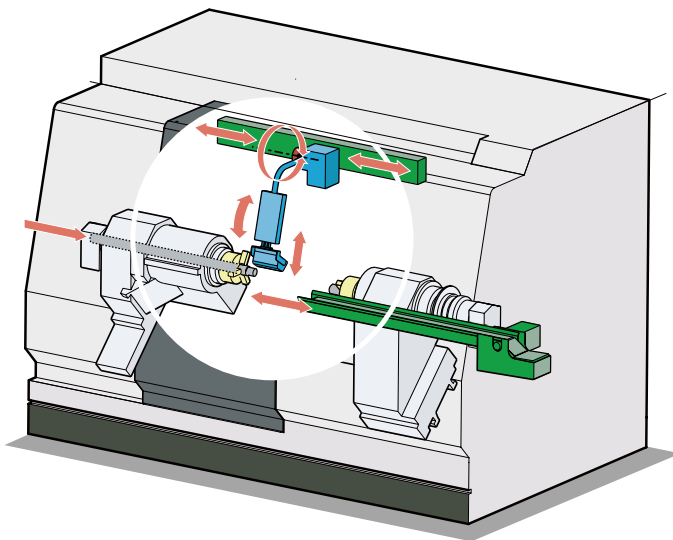
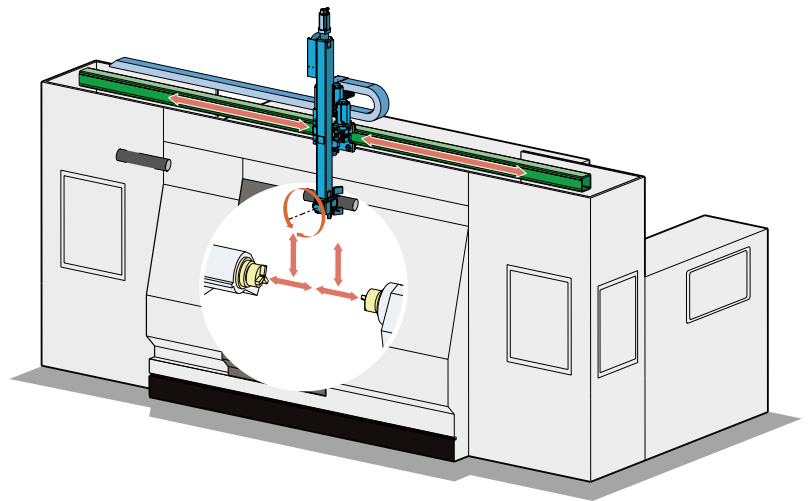

## Parts Unloader & Conveyor

Parts unloader system built inside the machine can receive workpieces from both spindles. Automated operation is realized perfectly when the system is coupled with bar feeder system.

Max. work diameter	Ø76 mm (3.0 inch)
Max. work length	170 mm (6.7 inch)
Max. work weight	4kg (8.8 lb)

## Bar Feeder System

Automated bar working is possible by bar feeder system. When parts unloader system is added, its value of use will be in the best.

Max. Bar Working dia

**Ø 76 mm (3.0 inch)**

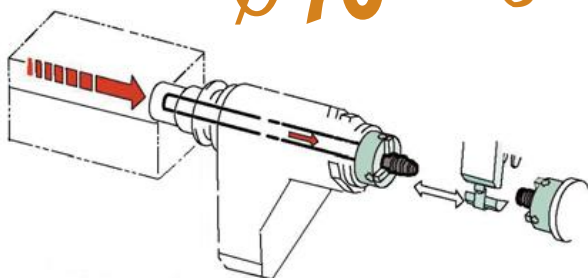

Note) Depending on the chuck and cylinder spec. used in the machine, the bar working dia. can be reduced.

## User-friendly OP Panel

The operation panel of new design enhances operating convenience by common buttons and layout, and uses qwerty type keyboard for easy and fast operation.

- 10.4 inches Display
- USB & PCMCIA card (standard)
- QWERTY keyboard (standard)
- Buttons can be easily added for additional options
- Operation panel newly designed for greater user convenience



10.4 inches Display

## EZ-Guide i

Using the DOOSAN EZ-Guide i, users can create a cutting program for any desired shape, including patterns, by entering figures only.

### Example programming

cutting shape

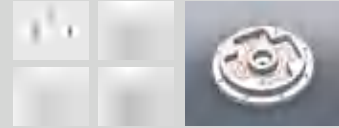

EZ-Guide i screen



Enter the dimensions of the shape.



Automatic creation of cutting program

O7000 (SAMPLE PROGRAM) ;

```
M3 S1500 ;
G0 X50. Y125. ;
G0 Z30. ;
G1040 T0.5 J3. H0.2 K0.5 ;
G1020 H120. V50. U37. W68. ;
G0 Z80. ;
M5 ;
```

A cutting program is automatically created with the entered values.

## Easy Operation Package

Doosan's Easy Operation Package (EOP) supports the user with functions relating to tool data, error diagnostics, set up and machine monitoring.

### Tool Load Monitoring Function

During cutting operation, abnormal load caused by wear or damage of the tool is detected and an alarm is triggered to prevent further damage.



Tool monitoring screen

### Tool Load Monitoring Function

The condition and service procedures of the sensors are provided for easy maintenance and servicing of major units.

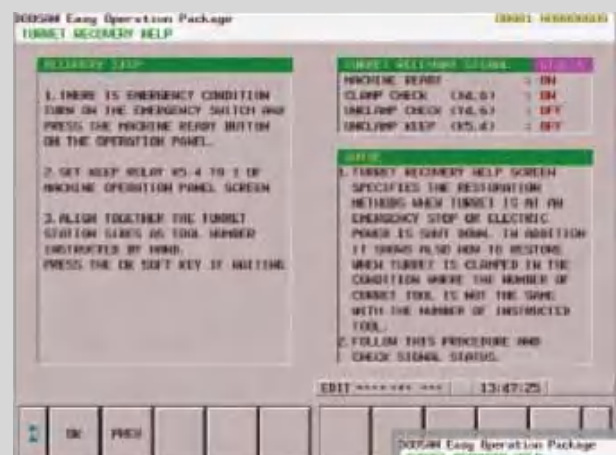

Turret maintenance and service screen

# Spindle power-torque diagram

## PUMA TT 2500S/MS/SY

- Spindle motor power : 26 kW (34.9 Hp) (Built-in)
- Max. Spindle speed : 35000 r/min

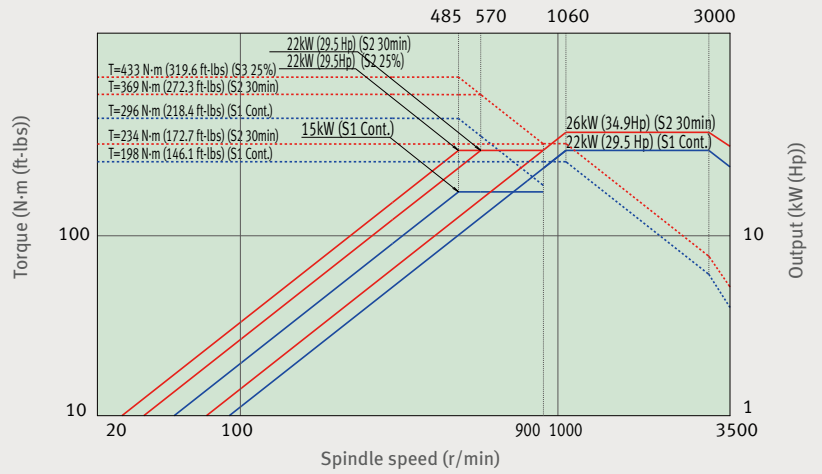

## Rotary tool spindle

## PUMA TT 2500 MS/SY

- Spindle motor power : 5.5/1.5 kW (7.4/2.0 Hp) (15min/Cont.)

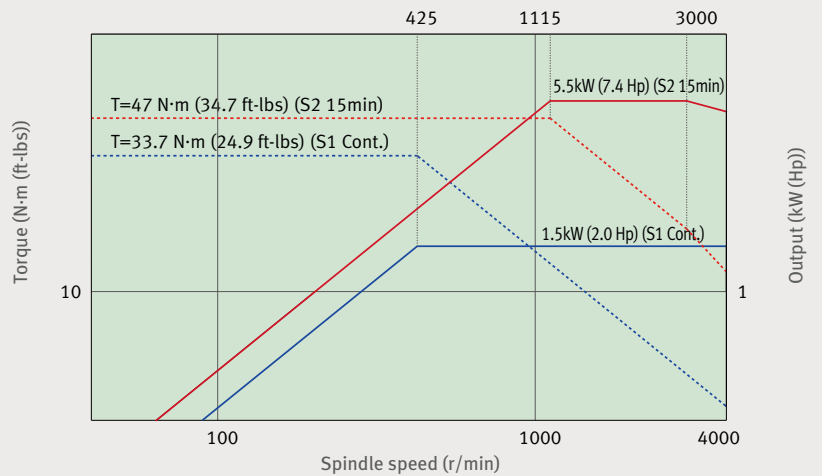

## PUMA TT 2500 MS/SY (option)

- Spindle motor power : 7.5/1.5 kW (10.1/2.0 Hp) (5min/Cont.)

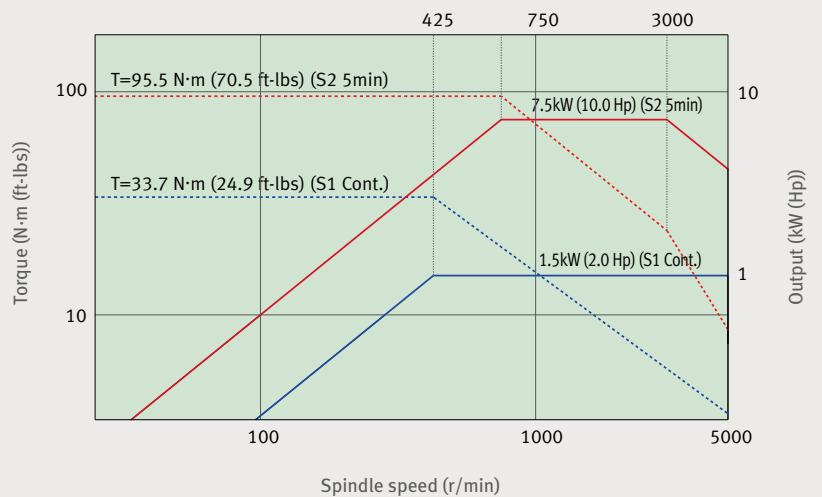

# External Dimensions

unit : mm (inch)

Top View

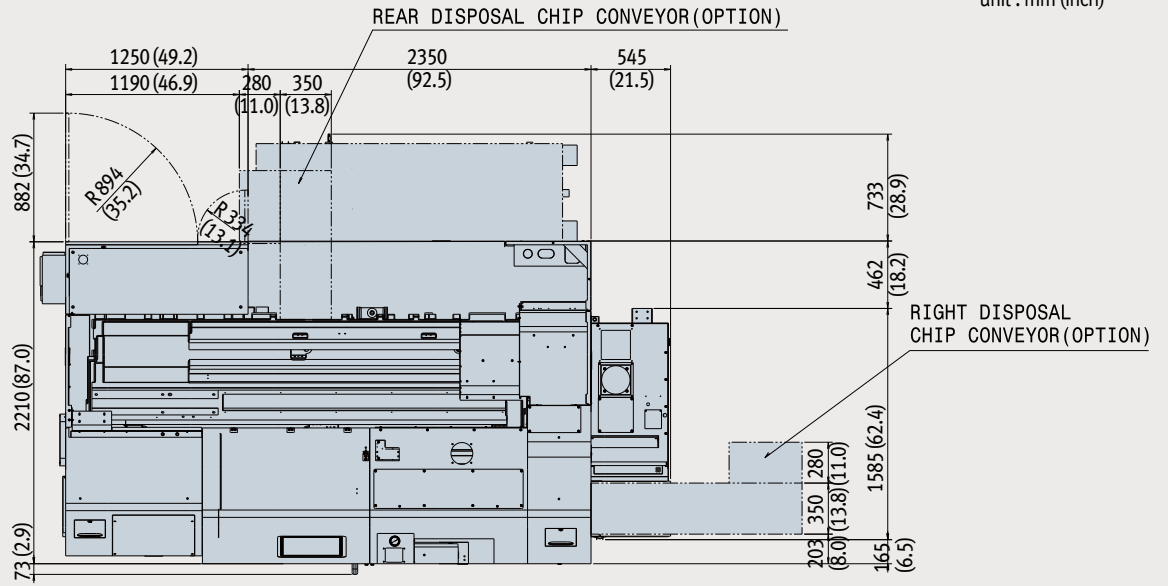

Front View

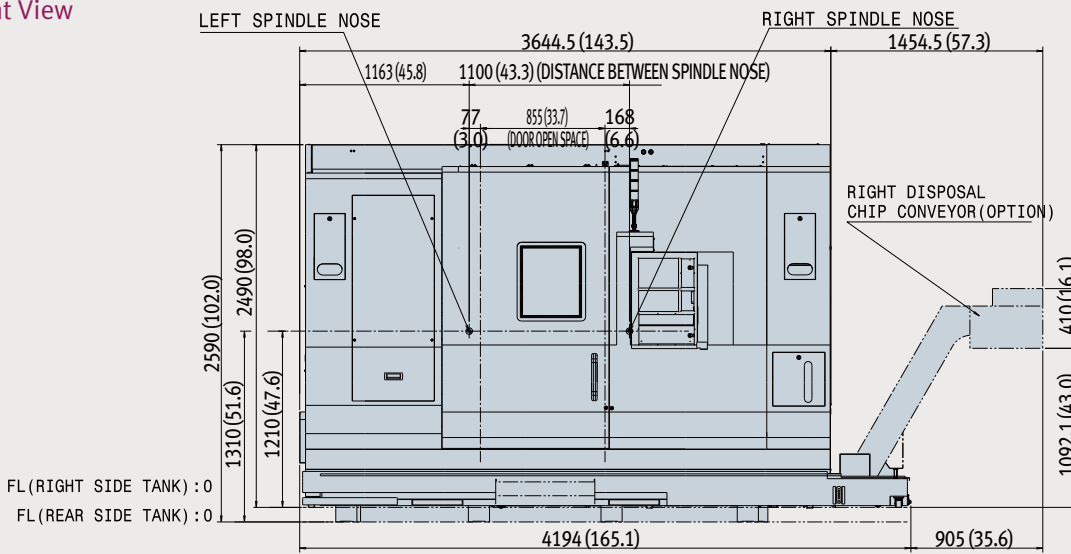

Side View

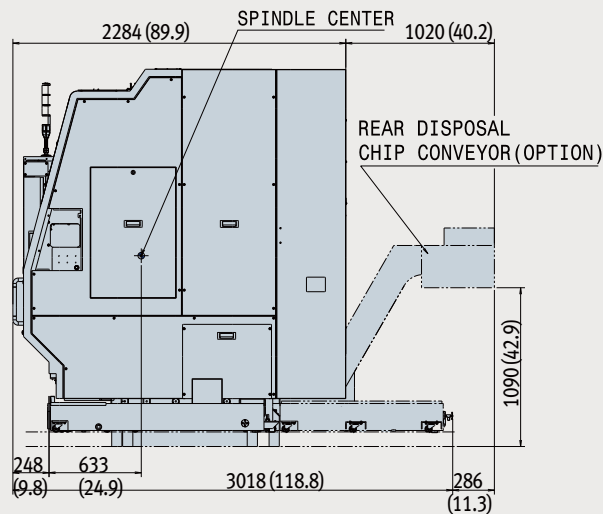

# Tooling System (Upper & Lower turret)

unit : mm (inch)

Standard

■ : MS/SY series

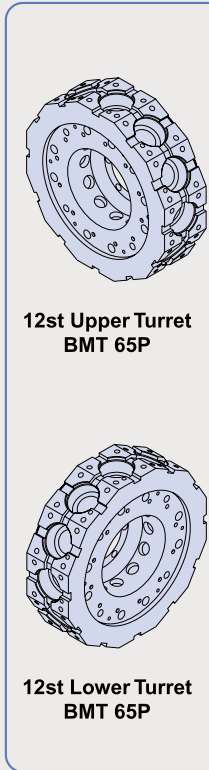

## TURNING TOOL

### OD, FACE, CUT-OFF

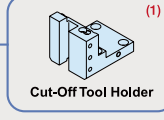
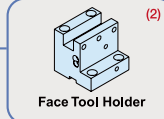
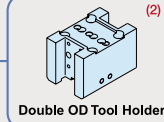
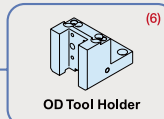

### ID HOLDER

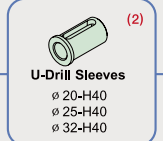
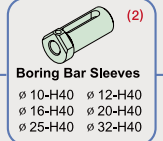
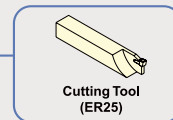
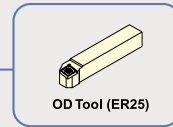
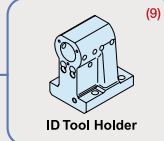

## ROTARY TOOL

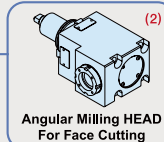
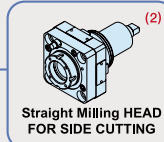

## PLUG

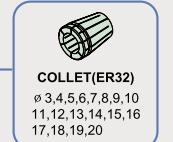
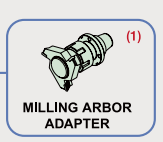
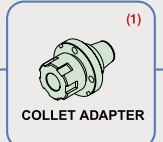

# Tool Interference Diagram

unit : mm (inch)

## PUMA TT 2500 S

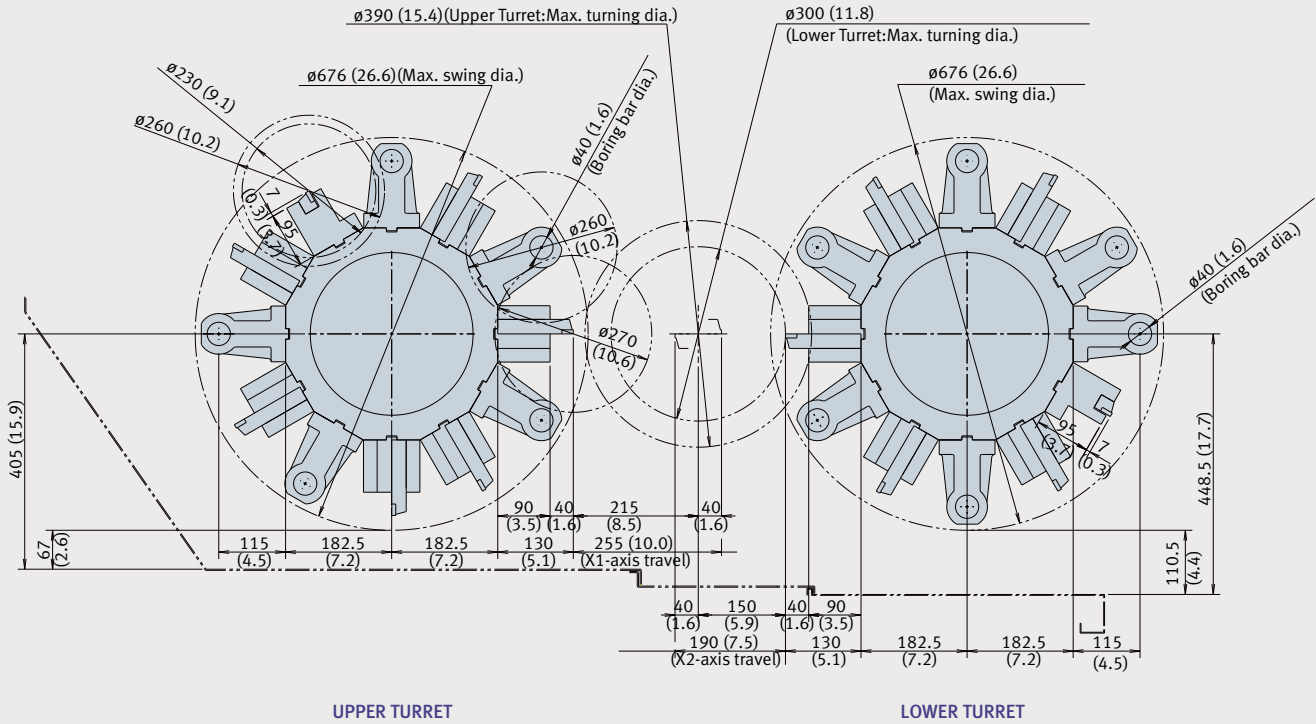

## PUMA TT 2500 MS/SY

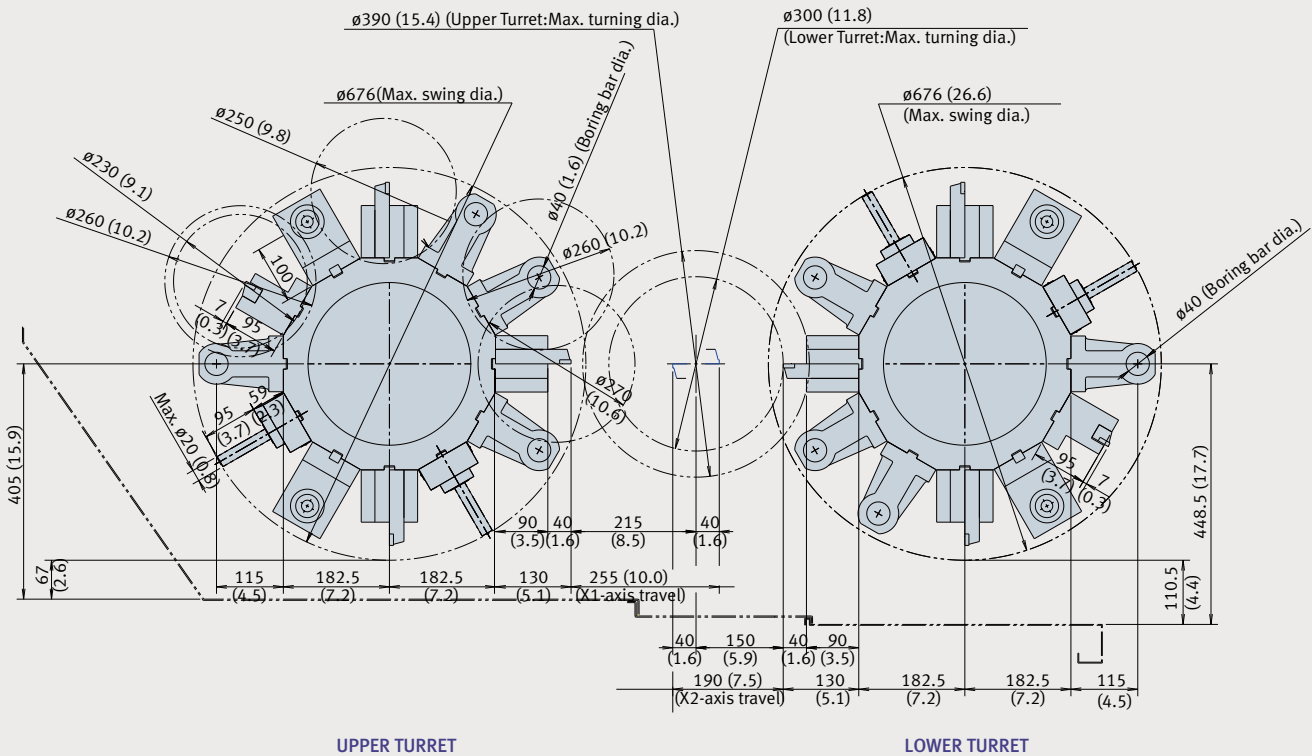



# Working Range

## PUMA TT 2500 S/MS/SY

unit : mm (inch)

### Single OD Tool holder

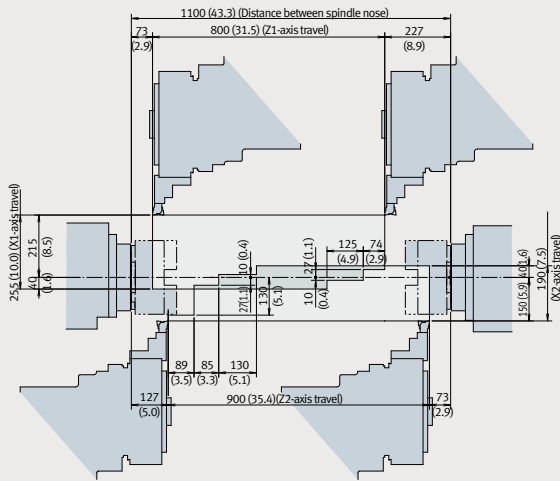

### Double OD Tool holder

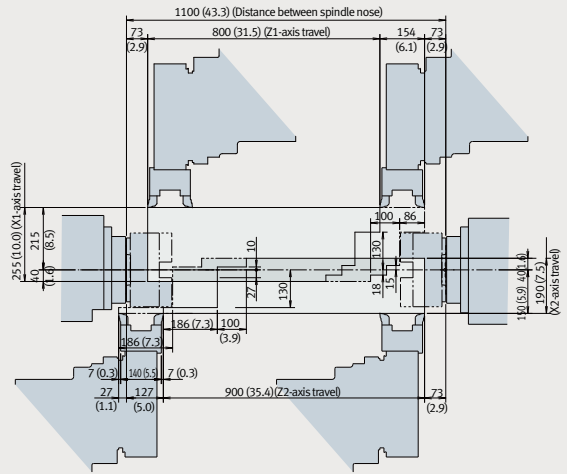

### Single ID Tool holder

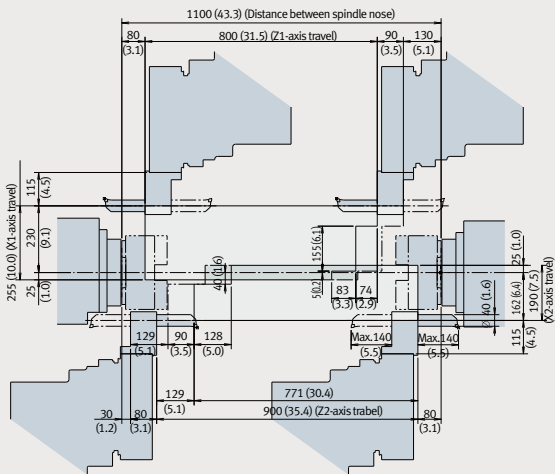

### Angular milling head

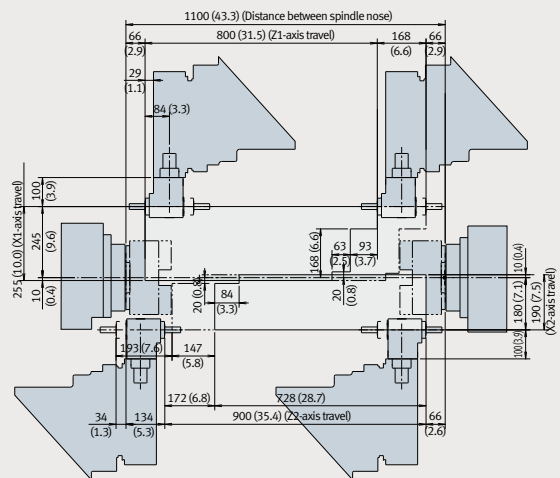

### Straight milling head

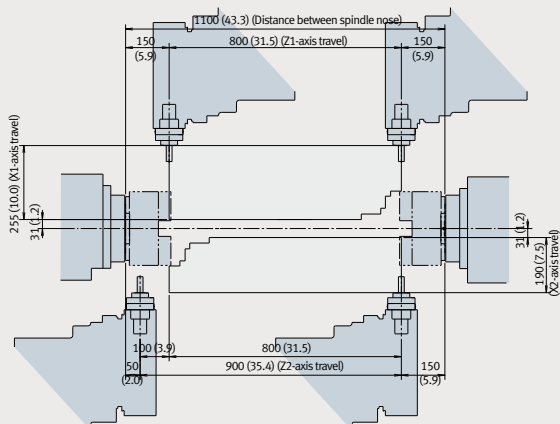

# Machine Specifications

Item	Unit	Specification			
		PUMA TT2500S	PUMA TT2500MS	PUMA TT2500SY	
Capacity	Swing over bed	mm (inch)	800 (31.5)		
	Swing over saddle	mm (inch)	620 (24.4)		
	Max. turning diameter	On upper turret	mm (inch)	390 (15.4)	
		On lower turret	mm (inch)	300 (11.8)	
	Recommended turning diameter	mm (inch)	255 (10.0)		
	Max. turning length	mm (inch)	350 (13.8)		
	Bar working diameter	mm (inch)	76 (3.0)		
Spindle (Left/Right)	Spindle speed	r/min	3500		
	Spindle nose	ASA	A2-8		
	Spindle bearing diameter (front)	mm (inch)	130		
	Spindle through hole diameter	mm (inch)	86		
	C1-axis minimum indexing increment	deg	-	0.001	
	Travels	X1-axis	mm (inch)	255 (10.0)	
Z1-axis		mm (inch)	800 (31.5)		
A-axis		mm (inch)	810 (31.9)		
X2-axis		mm (inch)	190 (7.5)		
Z2-axis		mm (inch)	900 (35.4)		
C1, C2-axis		deg	-	360	
Y-axis		mm (inch)	-	-	120 (±60) (4.7 (±2.4))
Rapid traverse rate		X1, 2-axis	m/min (ipm)	20 (787.4)	
	Z1, 2-axis	m/min (ipm)	24 (944.9)		
	A-axis	m/min (ipm)	24 (944.9)		
	C1, C2-axis	r/min	-	200	
	Y-axis	m/min (ipm)	-	75 (2952.8)	
Turret (Upper/Lower)	Number of tool stations	ea	12		
	OD tool size	mm (inch)	25 x 25 (1.0 x 1.0)		
	Max. boring bar size	mm (inch)	Ø40 (Ø1.6)		
	Turret indexing time	1 station swivel	sec	0.2	
	Max. rotary tool speed	r/min	-	4000	
	Motor	Spindle motor power (Left/Right)	kW (Hp)	26 / 22 (34.9 / 29.5) (30min/Cont.)	
Servo motor power		X1-axis	kW (Hp)	4 (5.4)	
		X2-axis	kW (Hp)	3 (4.0)	
		Z1, 2-axis	kW (Hp)	4 (5.4)	
		A-axis	kW (Hp)	4 (5.4)	
		Y-axis	kW (Hp)	-	3 (4.0)
Coolant pump motor power		kW (Hp)	0.4 (0.5)		
Power source		Required power capacity	kVA	95.77	
Machine Dimensions	Machine size	Floor space	4050 x 2210 (159.4 x 87.0)		
		Height	2480 (97.6)		
	Machine weight (Net) <sup>(1)</sup>	kg (lb)	12700 (27998.3)		

## Standard Feature

- |  |  |  |  |
|--|--|--|--|
| <ul style="list-style-type: none"> <li>• Absolute positioning coder</li> <li>• Air blower</li> <li>• Automatic coolant system</li> </ul> | <ul style="list-style-type: none"> <li>• Coolant supply equipment</li> <li>• Front guard door interlock</li> <li>• Hydraulic unit</li> </ul> | <ul style="list-style-type: none"> <li>• Machine level inspection plate</li> <li>• Soft jaws (total)</li> <li>• Spindle head cooling system</li> </ul> | <ul style="list-style-type: none"> <li>• Standard hydraulic chuck</li> <li>• Tools and tool box</li> <li>• Work light</li> </ul> |
|--|--|--|--|

## Optional Feature

- |  |   |   |   |
|--|---|---|---|
| <ul style="list-style-type: none"> <li>• Air conditioner for electric cabinet</li> <li>• Air gun</li> <li>• Automatic door</li> <li>• Automatic door with safety device</li> <li>• Automatic power off</li> <li>• Bar feeder interface</li> <li>• Chip Conveyor &amp; Chip Bucket</li> <li>• Chuck coolant</li> <li>• Collet chucks</li> </ul> | <ul style="list-style-type: none"> <li>• Dual chucking pressure</li> <li>• Electric cabinet light</li> <li>• Extra M-Code (4ea)</li> <li>• High pressure coolant</li> <li>• Linear Scale(X1/X2)</li> <li>• Minimum Quantity Lubrication (MQL)system</li> <li>• Oil mist collector</li> <li>• Oil skimmer</li> </ul> | <ul style="list-style-type: none"> <li>• Parts unloader and conveyor</li> <li>• Portable MPG</li> <li>• Proximity switches for chuck clamp confirmation</li> <li>• Robot interface (PMCI / O, PROFIBUS)</li> <li>• Signal Tower</li> <li>• Special chuck</li> <li>• Tail center for turret</li> </ul> | <ul style="list-style-type: none"> <li>• Through Spindle Coolant(T.S.C) For Spindle (Left / Right)</li> <li>• Tool Load Monitoring</li> <li>• Tool pre-setter</li> <li>• Work &amp; tool counter</li> <li>• Work ejector for right spindle</li> </ul> |
|--|---|---|---|

# NC Unit Specifications (FANUC 31i)

● Standard ○ Optional X Not applicable

NO.	Division	Item	Spec.	Fanuc 31i		
				S	MS	SY
1	Control axes	Control paths		2 Path	2 Path	2 Path
2		Controlled axes		5 (X1, Z1, X2, Z2, A)	7 (X1, Z1, C1, X2, Z2, C2, A)	8 (X1, Z1, C1, Y, X2, Z2, C2, A)
3		Simultaneously controlled axes		4 axes	4 axes	4 axes
4		Axis control by PMC		●	●	●
5		Cs contouring control		X	●	●
6		Synchronous/Composite control		●	●	●
7		Torque control		●	●	●
8		Increment system	ISA, IS-B	●	●	●
9		HRV2 control		●	●	●
10		Inch / metric conversion		●	●	●
11		Stored limit check before move		○	○	○
12		Chamfering on / off		●	●	●
13		Interference check for rotary area		●	●	●
14		Unexpected disturbance torque detection function		●	●	●
15		Position switch		●	●	●
16	Operation	Tool retract and recover		○	○	○
17		Dry run		●	●	●
18		Single block		●	●	●
19		Handle interruption		○	○	○
20		Incremental feed	x1, x10, x100	●	●	●
21		Manual handle retrace		○	○	○
22	Active block cancel		○	○	○	
23	Interpolation	Nano interpolation		●	●	●
24		Linear interpolation		●	●	●
25		Circular interpolation		●	●	●
26		Polar coordinate interpolation		●	●	●
27		Cylindrical interpolation		●	●	●
28		Helical interpolation		X	●	●
29		Thread cutting, synchronous cutting		●	●	●
30		Multi threading		●	●	●
31		Thread cutting retract		●	●	●
32		Continuous threading		●	●	●
33		Variable lead thread cutting		○	○	○
34		Circular thread cutting		○	○	○
35		Polygon machining with two spindles		●	●	●
36	High-speed skip	Input signal is 8 points.	○	○	○	
37	3rd/4th reference position return		○	○	○	
38	Balanced cutting	Only for more than 2 path control	●	●	●	
39	Feeding	Bell-shaped acceleration/ deceleration after cutting feed interpolation		●	●	●
40		Override cancel		●	●	●
41		AI contour control I		●	●	●
42		AI contour control II		○	○	○
43	Rapid traverse block overlap		●	●	●	
44	Program ming	Optional block skip	9 pieces	●	●	●
45		Absolute / incremental programming	Combined use in the same block	●	●	●
46		Diameter / Radius programming		●	●	●
47		Automatic coordinate system setting		●	●	●
48		Workpiece coordinate system	G52 - G59	●	●	●
49		Workpiece coordinate system preset		○	○	○
50		Addition of workpiece coordinate system	48 pairs	○	○	○
51		Addition of workpiece coordinate system	300 pairs	○	○	○
52		Direct drawing dimension programming		●	●	●
53		Chamfering / Corner R		○	○	○
54		Custom macro		●	●	●
55	Addition of custom macro common variables	#100 - #199, #500 - #999	●	●	●	

NO.	Division	Item	Spec.	Fanuc 31i		
				S	MS	SY
56	Program ming	Custom macro common variables between each path	Only for more than 2 path control. Included in Custom macro.	●	●	●
57		Interruption type custom macro		○	○	○
58		Canned cycle		●	●	●
59		Multiple repetitive cycles	G70-G76	●	●	●
60		Multiple repetitive cycles II	Pocket profile	●	●	●
61		Canned cycle for drilling		●	●	●
62		Automatic corner override		○	○	○
63		Custom software (Total amount of each path)	12MByte	●	●	●
64		Coordinate system shift		●	●	●
65		Direct input of coordinate system shift		●	●	●
66	Real time custom macro		○	○	○	
67	Pattern data input		○	○	○	
68	Interactive programming	EZ-Guide i (Conversational Programming Solution)		●	●	●
69		Easy Operation Package		●	●	●
70	Auxiliary/ spindle function	High-speed M / S / T / B interface		●	●	●
71		Waiting M codes of high-speed type	Only for more than 2 path control	●	●	●
72		Constant surface speed control		●	●	●
73		Spindle override	0 - 150%	●	●	●
74		Spindle orientation		●	●	●
75		Spindle synchronous control		●	●	●
76		Rigid tap		●	●	●
77		Arbitrary speed threading		○	○	○
78	Tool function / tool compensation	Tool offset pairs	99-pairs	●	●	●
79			128 / 200 / 400 / 499 / 999 pair	○	○	○
80		Common offset memory between each path	Only for more than 2 path control	●	●	●
81	Tool function / tool compensation	Tool offset		●	●	●
82		Tool radius/Tool nose radius compensation		●	●	●
83		Tool geometry / wear compensation		●	●	●
84		Automatic tool offset		●	●	●
85		Direct input of offset value measured B		●	●	●
86	Accuracy compensation function	Tool life management		●	●	●
87		Backlash compensation for each rapid traverse and cutting feed		●	●	●
88		Stored pitch error compensation		●	●	●
89	Editing operation	Part program storage size & Number of registerable programs	640M (256KB)_500 programs	○	○	○
90			1280M (512KB)_1000 programs	●	●	●
91			1MB / 2MB / 4MB / 8MB 1000 / 2000 / 4000 programs	○	○	○
92		Program protect		●	●	●
93	Password function		●	●	●	
94	Playback		○	○	○	
95	Memory card program edit & operation	Max 63 programs	●	●	●	
96	Data input / output	Fast data server		○	○	○
97		External data input		●	●	●
98		Memory card input / output		●	●	●
99		USB memory input / output		●	●	●
100	Automatic data backup		●	●	●	
101	Interface function	Embedded Ethernet		●	●	●
102		Fast Ethernet		○	○	○
103	Others	Display unit	10.4" color LCD	●	●	●
104	Robot interface	Robot interface with PMC I/O module		○	○	○
105		Robot interface with PROFIBUS-DP		○	○	○

## PUMA TT2500 series



Specification	UNIT	PUMA TT2500S / MS / SY
Max. turning diameter	mm (inch)	Upper turret: 390 (15.4) / Lower turret: 300 (11.8)
Max. turning length	mm (inch)	350 (13.8)
Bar working diameter	mm (inch)	76 (3.0)
Chuck size	inch	10
Spindle speed	r/min	3500
Spindle motor power (Left / Right)	kW (Hp)	26 / 22 (34.9 / 29.5) (30min / Cont.)
NC system	-	FANUC 31i



## Doosan Machine Tools

<http://www.doosanmachinetools.com>

[www.facebook.com/doosanmachinetools](https://www.facebook.com/doosanmachinetools)

### Optimal Solutions for the Future

#### Head Office

Yeonkang Bldg., 6th FL., 270, Yeonji-dong,  
Jongno-gu, Seoul, Korea  
Tel +82-2-3670-5345 / 5362  
Fax +82-2-3670-5382

#### Doosan Machine Tools China

Room 101,201,301, Building 39 Xinzhuan Highway  
No.258 Songjiang District, China Shanghai(201612)  
Tel +86 21-5445-1155  
Fax +86 21-6405-1472

#### Doosan Machine Tools Japan

#2412, Mita Kokusai Bldg. 1-4-28 Mita,  
Minato-ku, Tokyo 108-0073, Japan  
Tel +81 3 5730 9013  
Fax +81 3 5730 9016

#### Doosan Machine Tools America

19A Chapin Rd., Pine Brook, NJ 07058, U.S.A.  
Tel +1-973-618-2500  
Fax +1-973-618-2501

#### Doosan Machine Tools Europe

Emdener Strasse 24, D-41540 Dormagen, Germany  
Tel +49-2133-5067-100  
Fax +49-2133-5067-111

#### Doosan Machine Tools India

106 / 10-11-12, Amruthahalli, Byatarayanapura,  
Bellary road, Bangalore-560 092, India  
Tel +91-80-4266-0122 / 121 / 100



\* For more details, please contact Doosan Machine Tools.

\* The specifications and information above-mentioned may be changed without prior notice.

\* Doosan Machine Tools Co., Ltd. is a subsidiary of MBK Partners. The trademark  **DOOSAN** is used under a licensing agreement with Doosan Corporation, the registered trademark holder.