

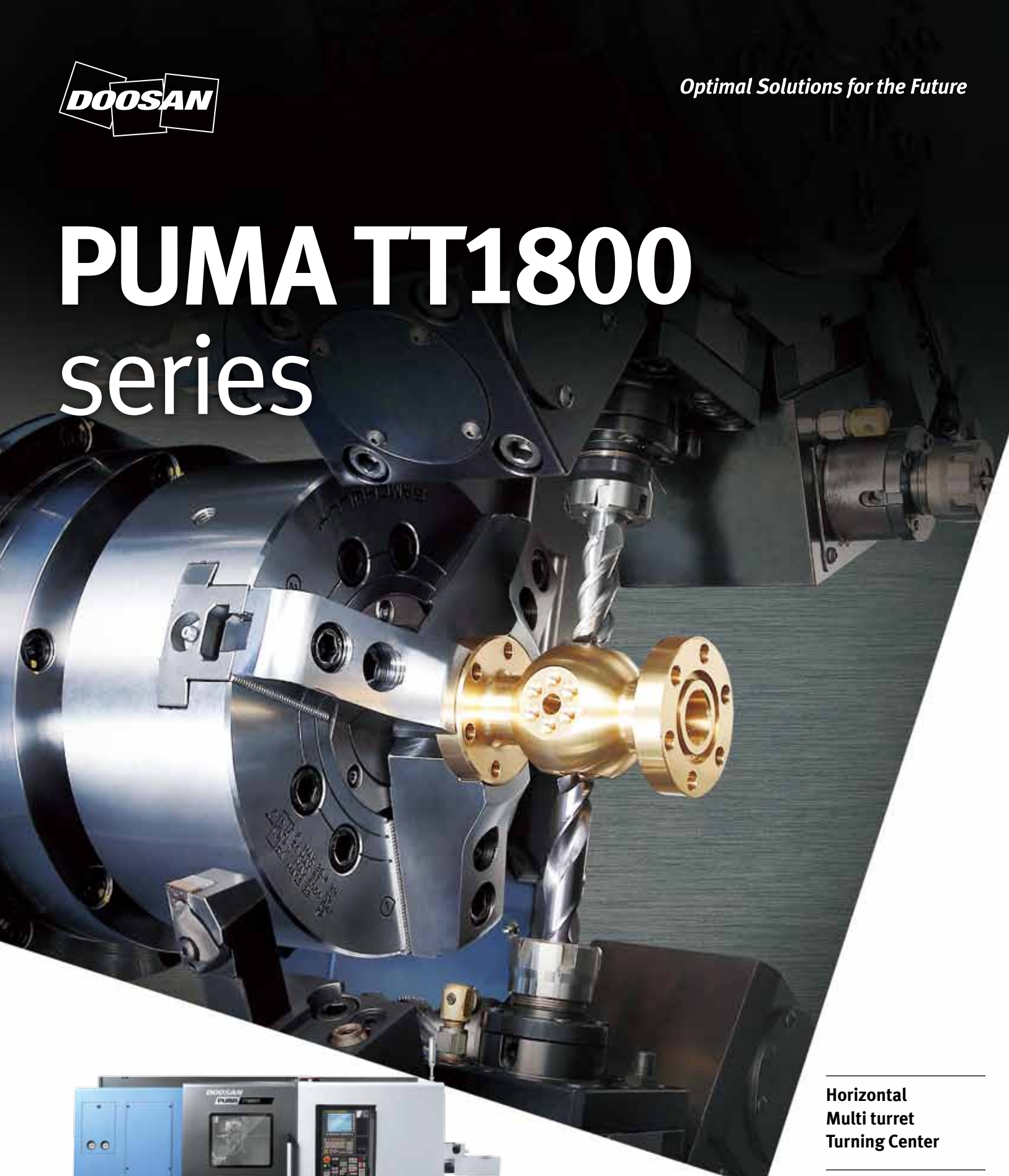

*Optimal Solutions for the Future*

# PUMA TT1800 series



---

**Horizontal  
Multi turret  
Turning Center**

---

**PUMA TT1800 series**

PUMA TT1800S  
PUMA TT1800MS  
PUMA TT1800SY

---

ver. EN 160502 SU

Basic Information

Basic Structure  
Line-up /  
Processing

Detailed  
Information

Options  
Applications  
Capacity Diagram  
Specifications

Customer Support  
Service



# PUMA TT1800 series

The Puma 1800 Series is a 65mm (2.6 inch) bar capacity high productivity horizontal turning center equipped with twin opposed spindles and upper / lower turrets. The left and right spindles can process work pieces independently to achieve excellent productivity. The work pieces processed by the left and right spindles are discharged via an automatic system. The PUMA TT Series has become one of DOOSAN's bestselling products and is favored by customers all around the world.



## Contents

### 02 Product Overview

#### Basic Information

#### 04 Basic Structure

#### 08 Line-up / Processing

#### Detailed Information

#### 11 Standard / Optional Specifications

#### 14 Applications

#### 17 Capacity Diagram

#### 22 Machine / NC Unit Specifications

### 26 Customer Support Service

#### Sample

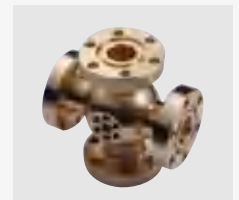

#### Productivity doubled with the adoption of a right spindle and a lower turret!

The left and right spindles and the upper and lower turrets operate independently to double the machine's productivity.

#### Excellent rigidity and power implemented with axis travel system optimization technology!

The product's rapid traverse rate of 40 m/min and High rigidity roller LM guide ways are designed to meet the required characteristics of machines whose users require a very high level of productivity.

#### Equipped with an advanced finished-part removal system for both spindles!

The left and right spindles are equipped with independent part catcher and unloader systems to provide a fully automated manufacturing system.

## Product overview

### Basic Information

Basic Structure  
Line-up /  
Processing

### Detailed Information

Options  
Applications  
Capacity Diagram  
Specifications

### Customer Support Service

# One machine, Two Processes

Two opposing spindles and upper and lower turrets installed on one machine

With the adoption of two opposing spindles and upper / lower turrets, the Puma TT Series can cut both first and second operations simultaneously. Furthermore, the axis travel system, which is designed with high rigidity roller guide ways and fast federate of 40m/min, provides a high level of thermal stability.

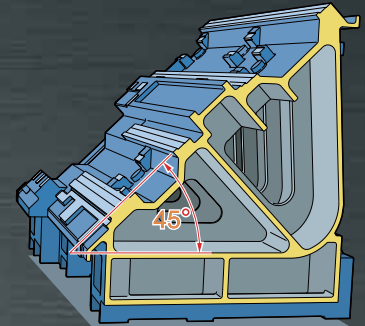

Designed as a wide-rib torque-tube structure to prevent twisting and deformation.



## Basic Structure

The Z, A axes are equipped with roller LM guide ways for increased rigidity and high speed, while the X and Y axes are equipped with box guide way for optimum rigidity, there by providing maximum productivity.

## Feed Axes Constitution

High productivity is achieved with a process-intensive structure comprising opposing types of spindles and upper and lower turrets.

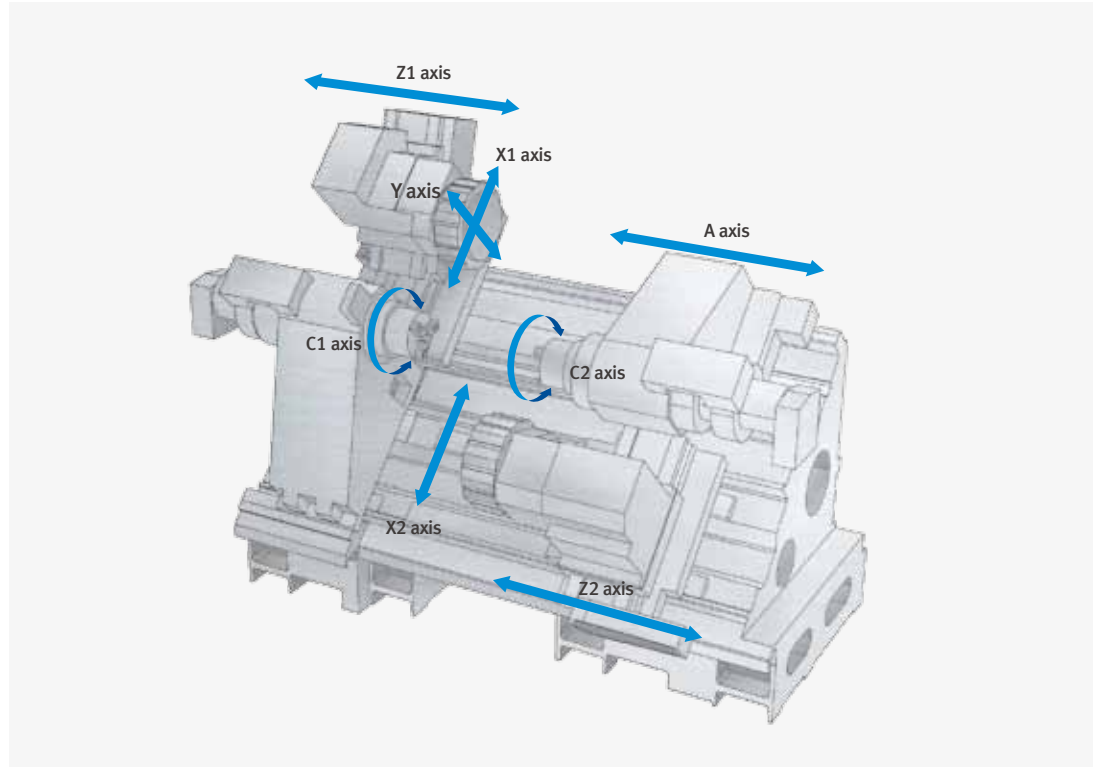

Description		Unit	PUMA TT1800S / MS	PUMA TT1800SY
Travel distance	X1, X2 axes	mm (inch)	X1: 165 (6.5) / X2: 190 (7.5)	
	Z1, Z2 axes	mm (inch)	Z1: 700 (27.6) / Z2: 720 (28.3)	
	Y axis	mm (inch)	-	100 (±50) (3.9 (±2.0))
	A axis	mm (inch)	770 (30.3)	
Rapid traverse rate	X1, X2 axes	m/min (ipm)	20 (787.4)	
	Z1, Z2 axes	m/min (ipm)	40 (1574.8)	
	Y axis	m/min (ipm)	-	7.5 (295.3)
	A axis	m/min (ipm)	40 (1574.8)	

## Ball Screw

The effects of changes of temperature on the travel system have been minimized with the optimized low friction balls crew design.



## LM Guide

high rigidity / high speed structure with roller LM guides on the Z and A axes.

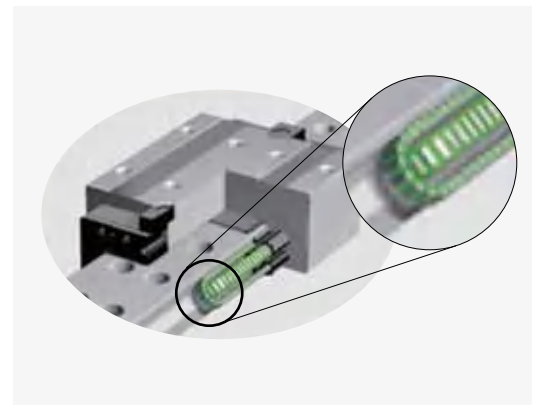

## Spindle

High productivity achieved with high-speed, high-power spindle motor.

### Built-in Structure

The PUMA TT series is equipped with built-in spindles to deliver high speed and responsiveness. Two opposing spindles provide the same turning performance characteristics using the same motors.

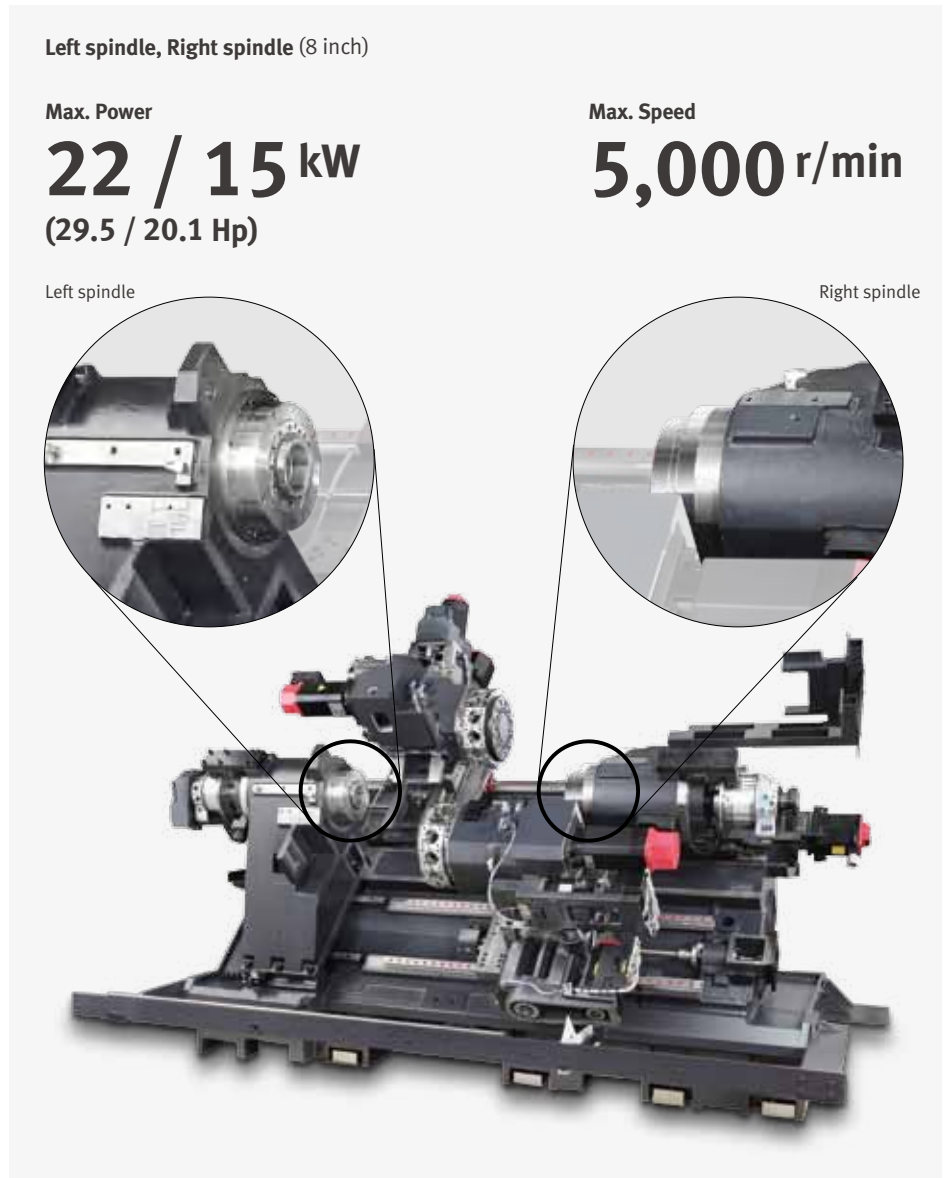

### C axis Accuracy

The positioning accuracy of the C axis has been enhanced by careful assembly of C-axis sensor and applying improved servo tuning.

#### Polar coordinate interpolation

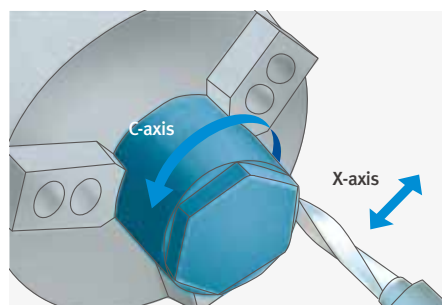

#### Cylindrical interpolation

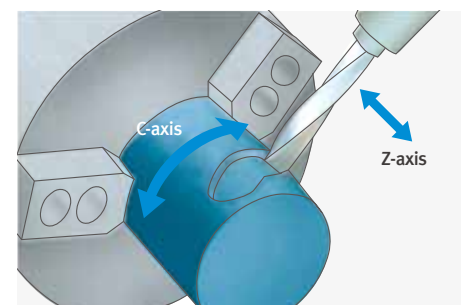

## Turret

Features stronger and faster turrets; upgraded servo motors for faster and more accurate tool rotation; and a stabilized structure for higher productivity and heavier-cutting capability.

### Turret with increased speed and rigidity

The upper and lower turrets double machine productivity by allowing independent, simultaneous operation.

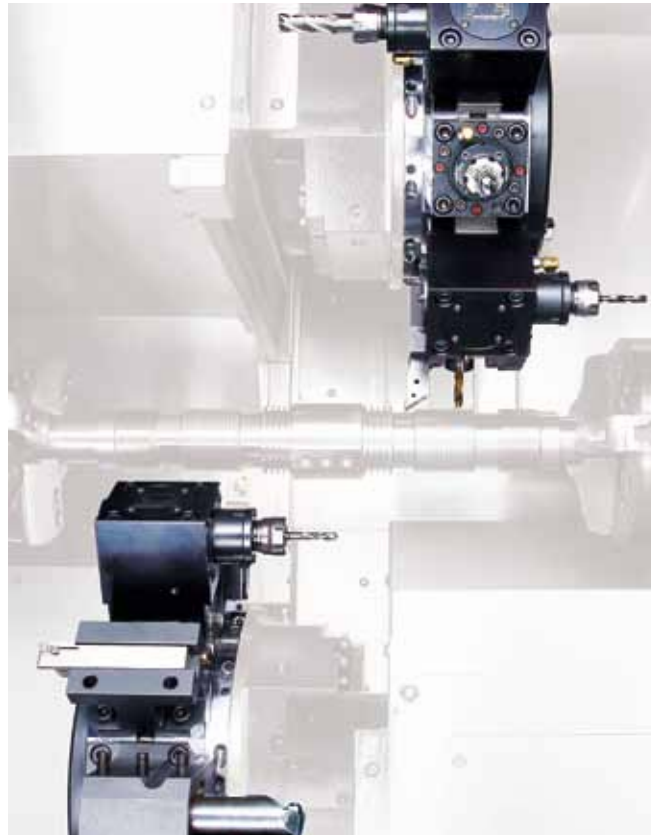

Turret indexing time (1 face)

**0.15s**

No. of tool station

(the same for the upper and lower turrets)

**12 station**

No. of index positions

(the same for the upper and lower turrets)

**24 index position**

### Turret with Upgraded Speed and Rigidity

The new turret has passed stricter speed and side loading tests. In addition, the cross-roller bearing reduces backlash and improves accuracy due to improved rigidity. Indexing time has been reduced by 20-30% compared with previous models.

Reduced non-cutting time

**10%**

Higher indexing speed

Improved accuracy



### Rotary Tool Structure Highly Resistant to Thermal Error

The milling turret including rotary tools features a BMT design standard for higher rigidity. In addition, the minimization of thermal error due to oil and air lubrication of the rotary tools delivers the best milling, drilling and tapping performance in its class.

Product overview

Basic Information

Basic Structure  
Line-up /  
Processing

Detailed  
Information

Options  
Applications  
Capacity Diagram  
Specifications

Customer Support  
Service

# Diverse Line-up Large capability

Rotary tools can be selected for milling, tapping and drilling, while Y axis can be used for cutting slanting or curved surfaces. A process-intensive turning center capable of conducting multiple processes, further widening the choices of machining processes.

Variation

○ Standard X Not Applicable

Specification	PUMA TT1800S	PUMA TT1800MS	PUMA TT1800SY
Chuck Size	8 inch	8 inch	8 inch
Left spindle	○	○	○
Right spindle	○	○	○
Upper / lower turrets	○	○	○
Rotary tool	X	○	○
Upper Y axis	X	X	○



Large capability

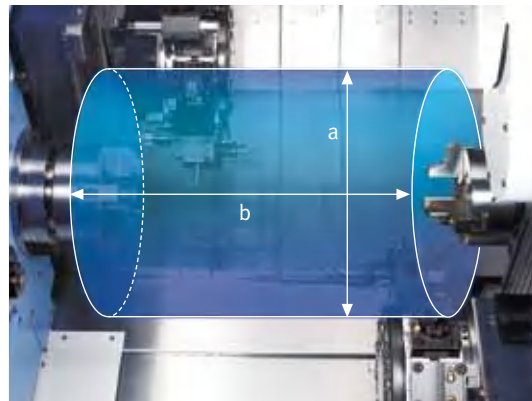

(a) max. turning diameter of  
**230mm (9.1 inch)**

(b) max. turning length of  
**230mm (9.1 inch)**

bar working diameter of  
**65mm (2.6 inch)**

Y-axis Milling

Wide variety of multi axis milling cycles can be achieved using the Y axis on the top turret.

Y-axis stroke

**100 (±50) mm**  
**(3.9 (±2.0) inch)**

Y-axis rapid traverse rate

**7.5 m/min**  
**(295.3 ipm)**

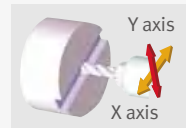

Groove finish cutting using the Y-axis

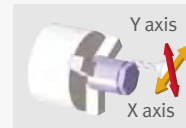

Multi-face cutting



Milling in an eccentric position

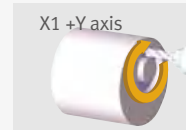

Y & X axes circular interpolation

Mill-turning

- Live tool holders are a BMT standard, with many tool holder configurations available. (angled holders, multi spindle holders, etc)
- Polar milling and Cylindrical milling are standard on machine.

Cutting Concept

Multi tasking with Right /Left spindle and Upper /Lower turret optimizes productivity.

Long shaft machining concept by synchronising the rotation of both spindles

PUMA TT Series turning centers can double the user's productivity by holding long workpieces securely with synchronized control of the left and right spindles and simultaneous cutting with the upper and lower turrets.



Turning at the same position is carried out with the upper and lower turrets simultaneously.



Different cutting processes can be carried out on a single work piece with the upper and lower turrets simultaneously.

## Complex machining with left and right hand spindles, upper and lower turrets

### Basic Information

Basic Structure  
Line-up /  
Processing

### Detailed Information

Options  
Applications  
Capacity Diagram  
Specifications

### Customer Support Service

#### Left spindle

Upper /  
Lower turret  
simultaneously  
machining with  
left spindle



#### Right spindle

Upper /  
Lower turret  
simultaneously  
machining with  
right spindle



### first process and second process simultaneously machining concept

it can time milled features from spindle to spindle (example : bolt hole pattern on right spindle to a keyway machined from the left spindle)



#### First process

Cutting with the left spindle



#### Part transfer

Synchronized rotation and parts feed using  
the left and right spindles

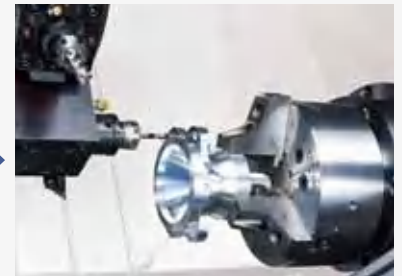

#### Second process

Rear side cutting with the right spindle  
(First process have being cutting with left spindle)

### one machine, two parts concept (same process, same cutting)

PUMA TT Series turning centers double the user's productivity thanks to the independent yet simultaneous operation of the left and right spindles and the upper and lower turrets.

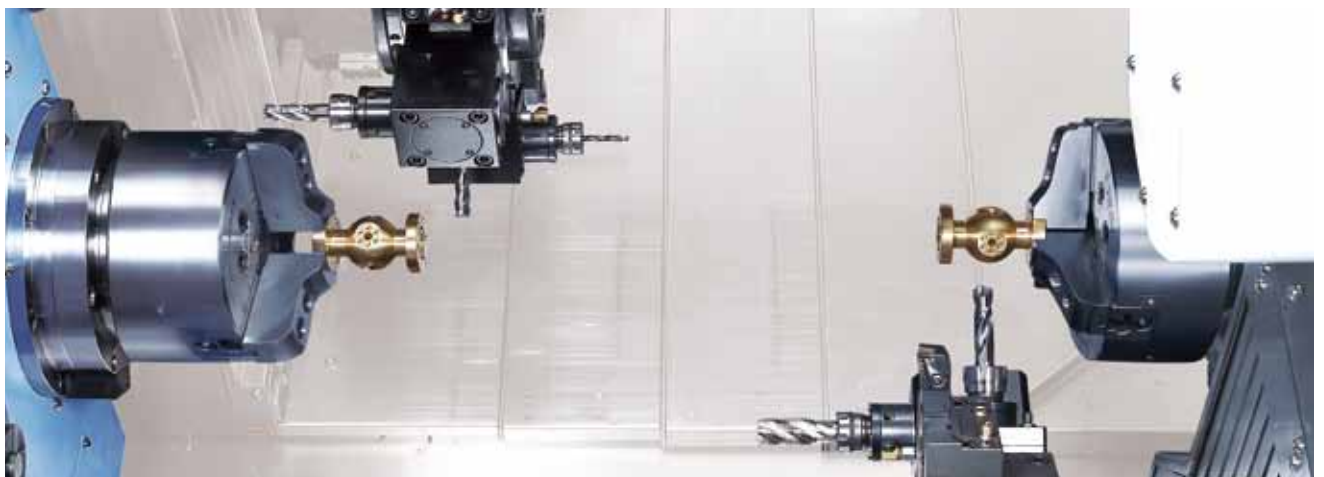



## Standard / Optional Specifications

Various options are available to satisfy all the customers' requirements.

● Standard ○ Optional X N/A

NO.	Description	Features	PUMA TT1800series
1	Chuck (Left / Right)	210 mm (8 Inch)	●
2		None	○
3	Jaws (Left / Right)	Soft Jaws	●
4		Hardened & Ground Hard Jaws	○
5	Chucking option	Dual Pressure Chucking	○
6		Chuck Clamp Confirmation	●
7	Tailstock	Tail Center For Turret	○
8	Coolant Pump (60 / 50Hz)	4.5 / 3.0 Bar	●
9		7 / 5, 10 / 7, 14.5 / 10, 28 / 19.5, 70 / 70 bar	○
10	Coolant options	Oil Skimmer	○
11		Coolant Chiller	○
12		Coolant Pressure Switch	○
13		Coolant Level Switch	○
14		Cooling Flow Switch	○
15		High Coolant Interface	○
16		Chuck Coolant (Left / Right)	○
17		Through Spindle Coolant(T.S.C) For Spindle (Left / Right)	○
18		Coolant Gun	○
19	Chip processing options	Chip Conveyor_Side Type	○
20		Chip Conveyor_Rear Type	○
21		Chip Bucket	○
22		Air Blow (Left / Right)	○
23		Mist Collector	○
24	Measurement & Automation	Tool Setter (Manual / Auto)	○
25		Parts Catcher And Box	○
26		Parts Unloader And Conveyor	○
27		Work Ejector	○
28		Auto Door	○
29		Cut-Off Confirmation	○
30		Work / Tool Counter	○
31		Robot Interface (PMC I/O, Profibus)	○
32		Bar Feeder Interface	○
33	Optional devices	Tool Load Monitoring	○
34		Linear Scale (X1, X2, Z1, Z2, Y)	○
35		Signal Tower	○
36		Air Gun	○
37		Air Conditioner For Electric Cabinet	○
38		Light For Electric Cabinet	○
39		Extra M-Code (4ea)	○
40		Auto Power Off	○

\* For further details of the range of options, please contact Doosan.

Peripheral equipments

Basic Information

Basic Structure  
Line-up /  
Processing





Detailed Information

Options  
Applications  
Capacity Diagram  
Specifications

Customer Support Service

Chip Conveyor (right side) **option**

The chip conveyor boasts excellent chip disposal performance, a stable design, and superior operation and maintenance convenience. Users can select the optimal type for specific requirements to improve the efficiency of their work space.

Name	Hinged belt	Magnetic scrapper	Drum filter (single type)	Drum filter (double type)
Application	Steel	Cast steel, iron	Cast	Steel, cast, nonferrous metals
Features	- General use - Suitable for steel works producing 30 mm chips or longer	- Easy-to-understand manual - Chips are scraped up and discharged	- Suitable for sludge - Suitable for nonferrous metals	- Suitable for long and short chips - Cooling water filtering function
Shape				

Coolant Chiller (recommended) **option**

A detachable-type coolant chiller is recommended to control temperature and minimize thermal error.

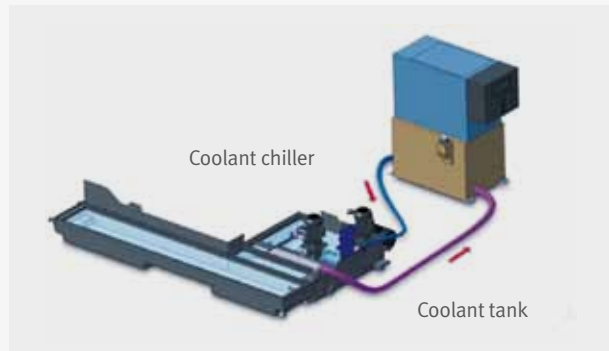

70 Bar High Pressure Coolant **option**

70 bar high pressure coolant suitable for high productivity.



Optional devices **option**

Auto tool setter



Coolant Blower



Signal tower



Collet Chuck



Oil skimmer



Mist Collector



Work Ejector

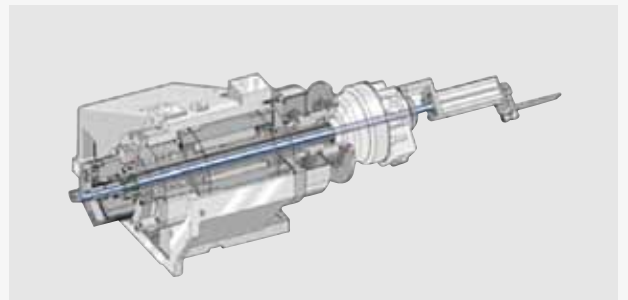

### Left Spindle Parts Catcher option

Single operation part produced on the left spindle, or bar remnant can be ejected into the bucket.

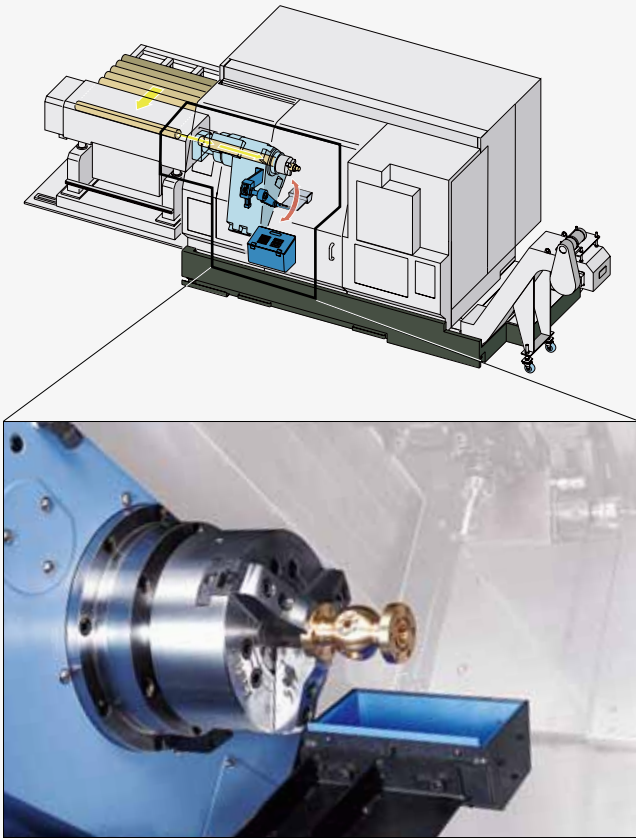

### Right Spindle Parts Unloader and Work Ejector option

Work processed by the right spindle is delivered to the parts unloader by the work ejector and then discharged to the parts conveyor.

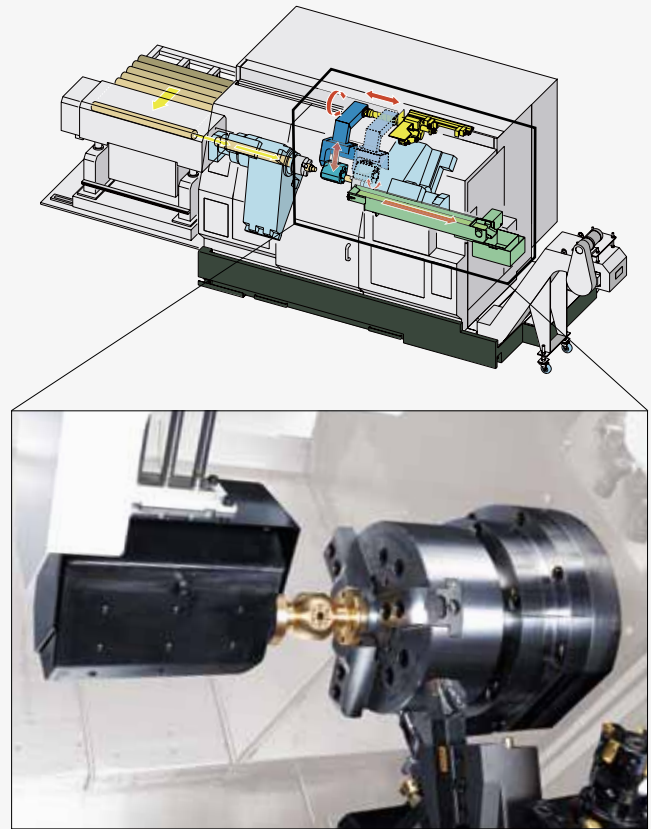

### Parts Conveyor option

Finished workpieces are transferred to the indexable output belt conveyor which discharges them to a receiving container.

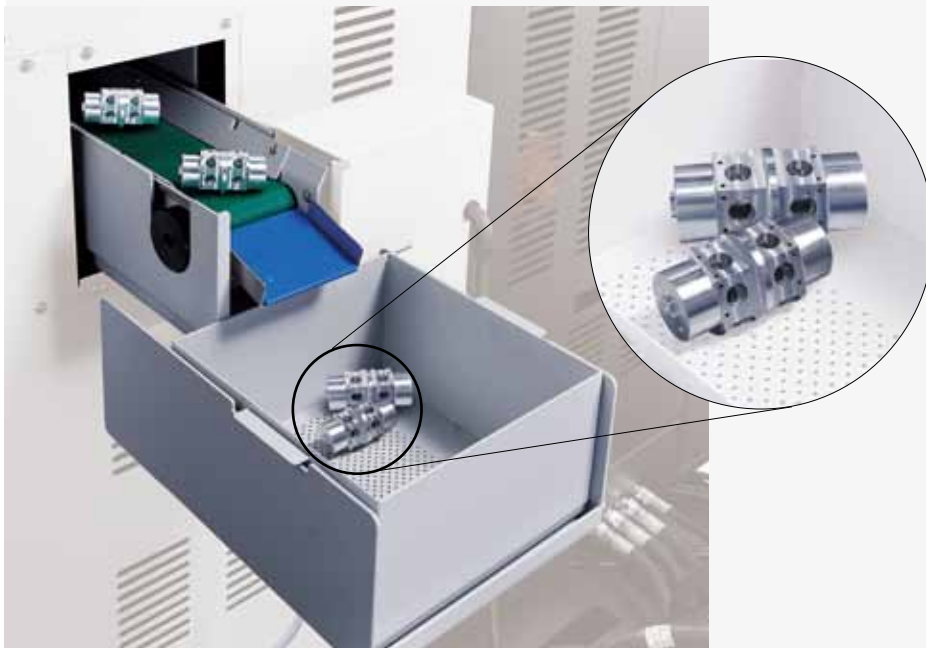

Maximum material size for unloader / conveyor system

Max. work diameter

**Ø65 mm (2.6 inch)**

Max. work length

**150 mm (5.9 inch)**

Max. work weight

**3kg (6.6 lb)**

Product Overview

Basic Information

Basic Structure  
Line-up /  
Processing

Detailed Information

Options  
Applications  
Capacity Diagram  
Specifications

Customer Support Service



# FANUC 31i

FANUC CNC optimized for DOOSAN's machine tools maximizes users' productivity.

## User-friendly OP Panel

The operation panel of new design enhances operating convenience by common buttons and layout, and uses qwerty type keyboard for easy and fast operation.

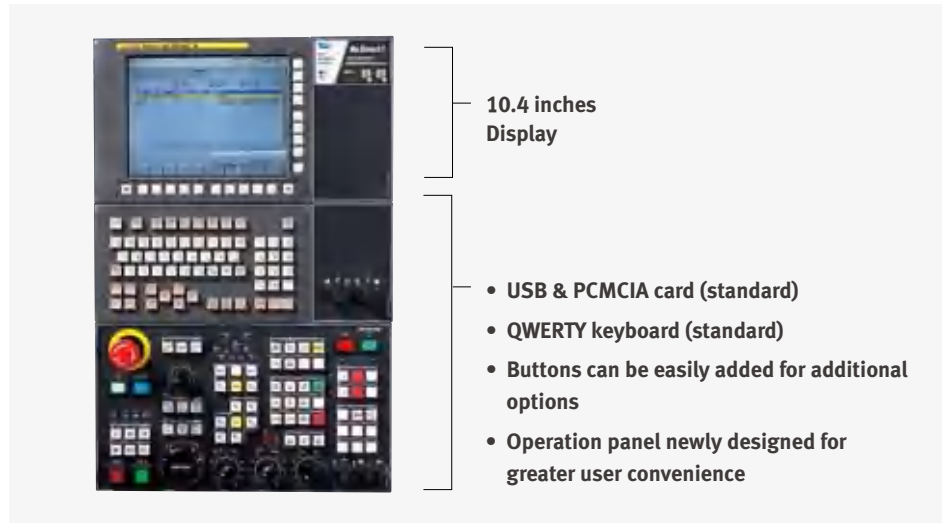

## Productivity Improvement

non-cutting time has been reduced by speeding up individual machine element operating speeds and increasing acceleration / deceleration characteristics.

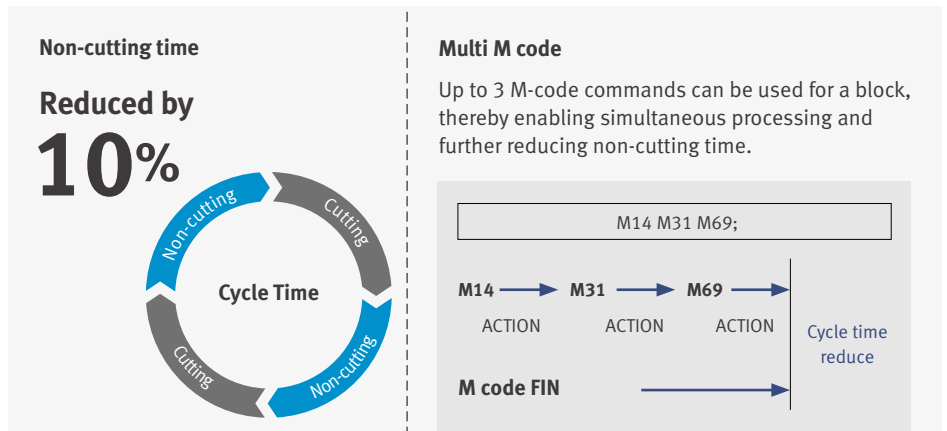

## Real time custom macro function option

During operation of the parts unloader of the right spindle, this function allows the lower turret to conduct the cutting operation for the left spindle. This function also further improves the productivity.

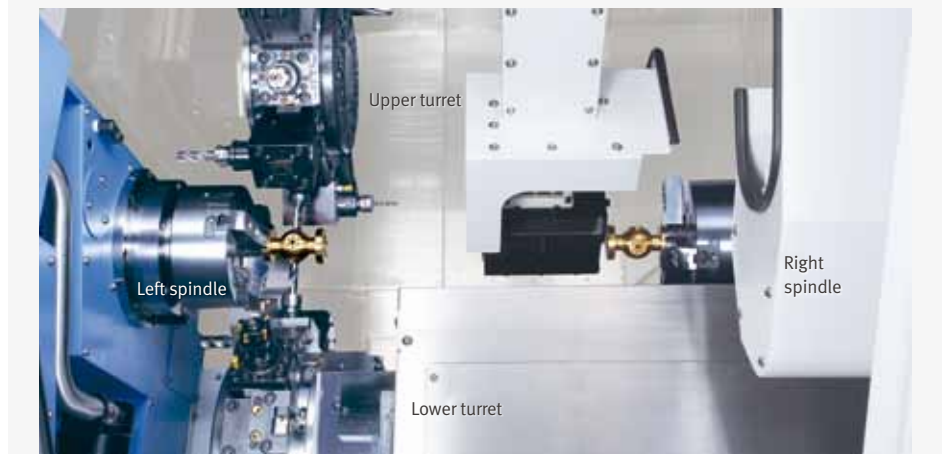

## EZ-Guide i

Using the DOOSAN EZ-Guide i, users can create a cutting program for any desired shape, including patterns, by entering figures only.

**Example programming**

**Cutting shape**

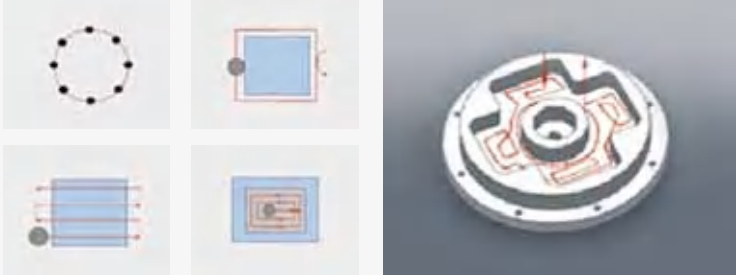

**EZ-Guide i screen**

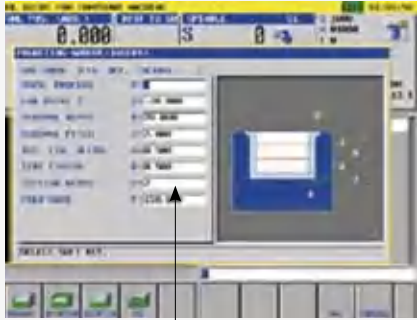

Enter the dimensions of the shape.

**Automatic creation of cutting program**

```
O7000 (SAMPLE PROGRAM) ;
...
M3 S1500 ;
G0 X50. Y125. ;
G0 Z30. ;
G1040 T0.5 J3. H0.2 K0.5 ... ;
G1020 H120. V50. U37. W68. ... ;
G0 Z80. ;
M5 ;
```

A cutting program is automatically created with the entered values.

## Easy Operation Package

Doosan's Easy Operation Package (EOP) supports the user with functions relating to tool data, error diagnostics, set up and machine monitoring.

### Tool Load Monitoring Function

During cutting operation, abnormal load caused by wear or damage of the tool is detected and an alarm is triggered to prevent further damage.



TOOL ID	TOOL NAME	LOAD %
001	TOOL 001	100%
002	TOOL 002	100%
003	TOOL 003	100%
004	TOOL 004	100%
005	TOOL 005	100%
006	TOOL 006	100%
007	TOOL 007	100%
008	TOOL 008	100%
009	TOOL 009	100%
010	TOOL 010	100%

Tool monitoring screen

### Convenience of Maintenance and Service

The condition and service procedures of the sensors are provided for easy maintenance and servicing of major units.



1. CHECK TO CONDUCT CONDITION CHECK ON THE TURRET UNIT AND PRESS THE MAINTENANCE SERVICE ON THE OPERATION PANEL.
2. SET UP THE TURRET TO 1 OF THE MAINTENANCE SERVICE.
3. HOLD TOGETHER THE TURRET STOP AND ELECTRIC POWER TO HOLD DOWN IN INDUCTION TO CHECK THE TURRET POSITION.
4. FOLLOW THE PROCEEDING AND CHECK SERVICE STATUS.

Turret maintenance and service screen



## SIEMENS 840D

SIEMENS CNCs have been adopted and optimized for DOOSAN's machine tools to maximize users' productivity.

### Large 19-inch Screen

Two path programs are displayed simultaneously in the large 19-inch screen for enhanced user convenience.

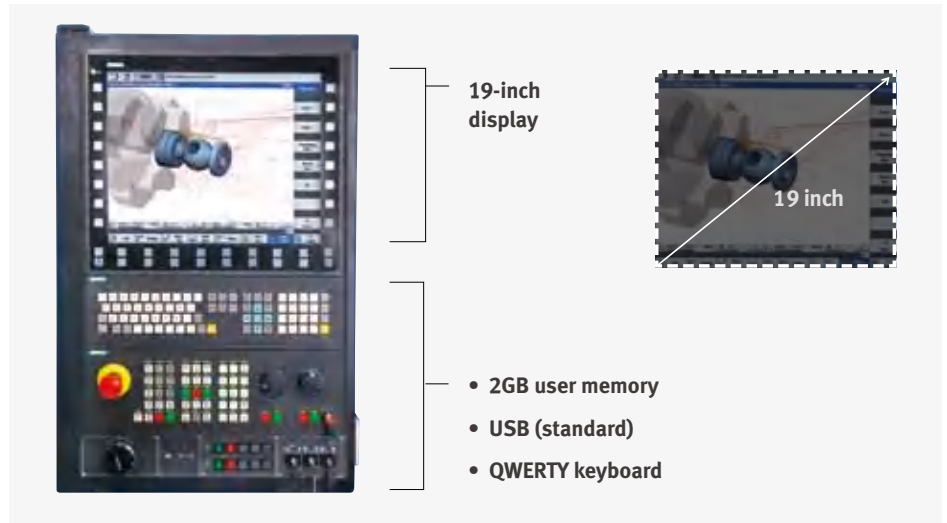

### Conversational Convenient function

The machining monitoring function developed on the basis of the Shop Turn – an interactive machining support function of SIEMENS – provides users with cutting, servicing and maintenance screens for easy and convenient machine operation.

#### Cutting and operation support function



This function shows a cutting and tool path simulation of a cutting program on a real-time basis.



The automation units (parts catcher, parts unloader) can be easily controlled via interactive windows.

Shop-turn mode[various] → [attachments]

#### Operation safety function



Protection Zone Synchronized Actions checks the interference between the turret and the spindle to prevent collisions that can be caused by the operator.

[Custom] → [Protection zones]

#### Maintenance and service convenience function



Maintenance and service of major units and peripheral devices, timer setting and parts counter setting can be easily carried out on a convenient screen.

[offset] → [operating parameter] → [TC service]

#### Machining accuracy improvement



The NC controls spindle speed at an optimal level for precision threading and turning, making it possible to improve surface roughness automatically.

[various] → [attachment] → [DSSV]

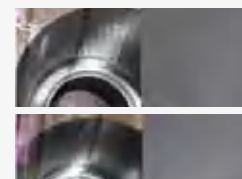

Before applying the function

After applying the function



## Spindle Power-Torque Diagram

### FANUC

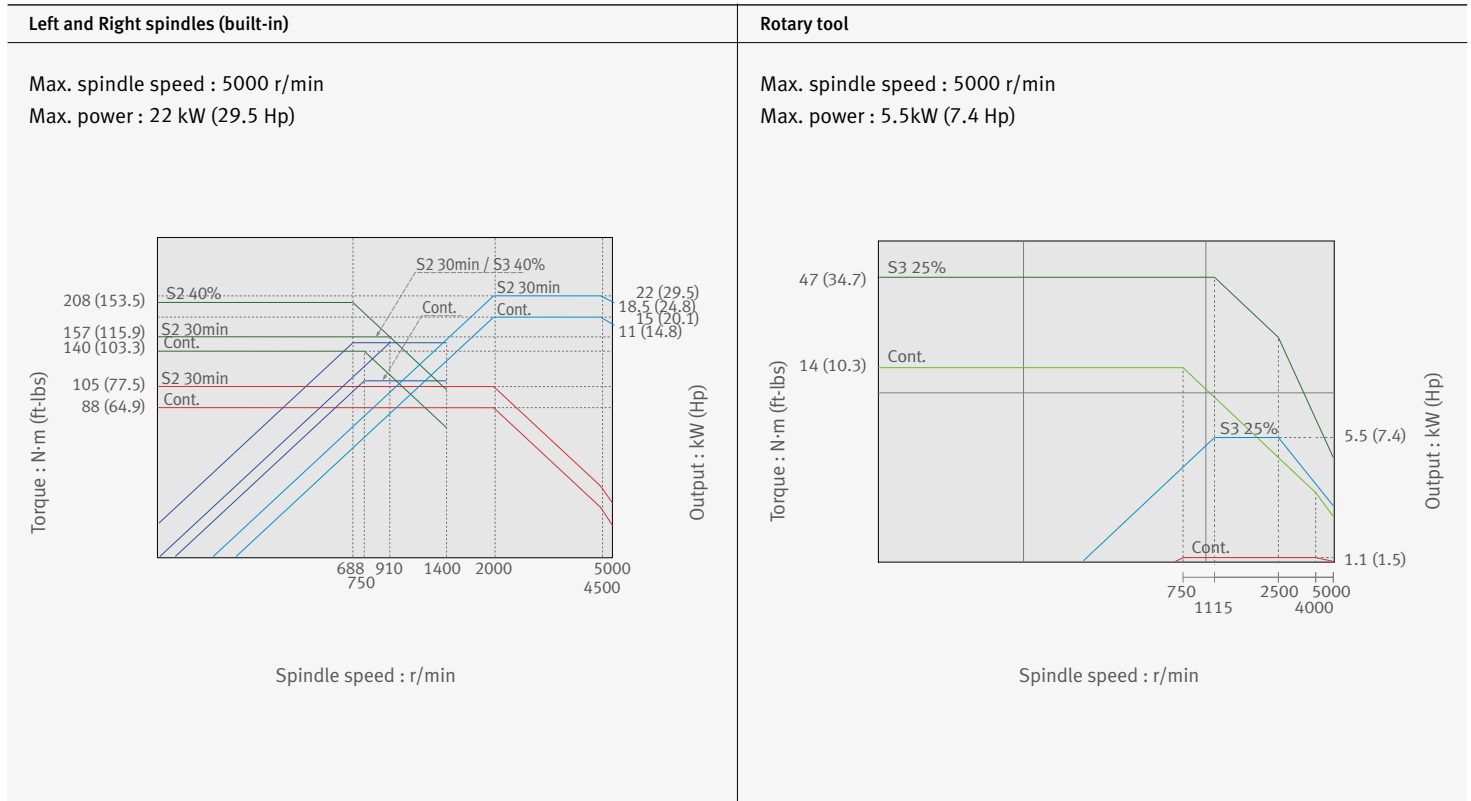

### SIEMENS

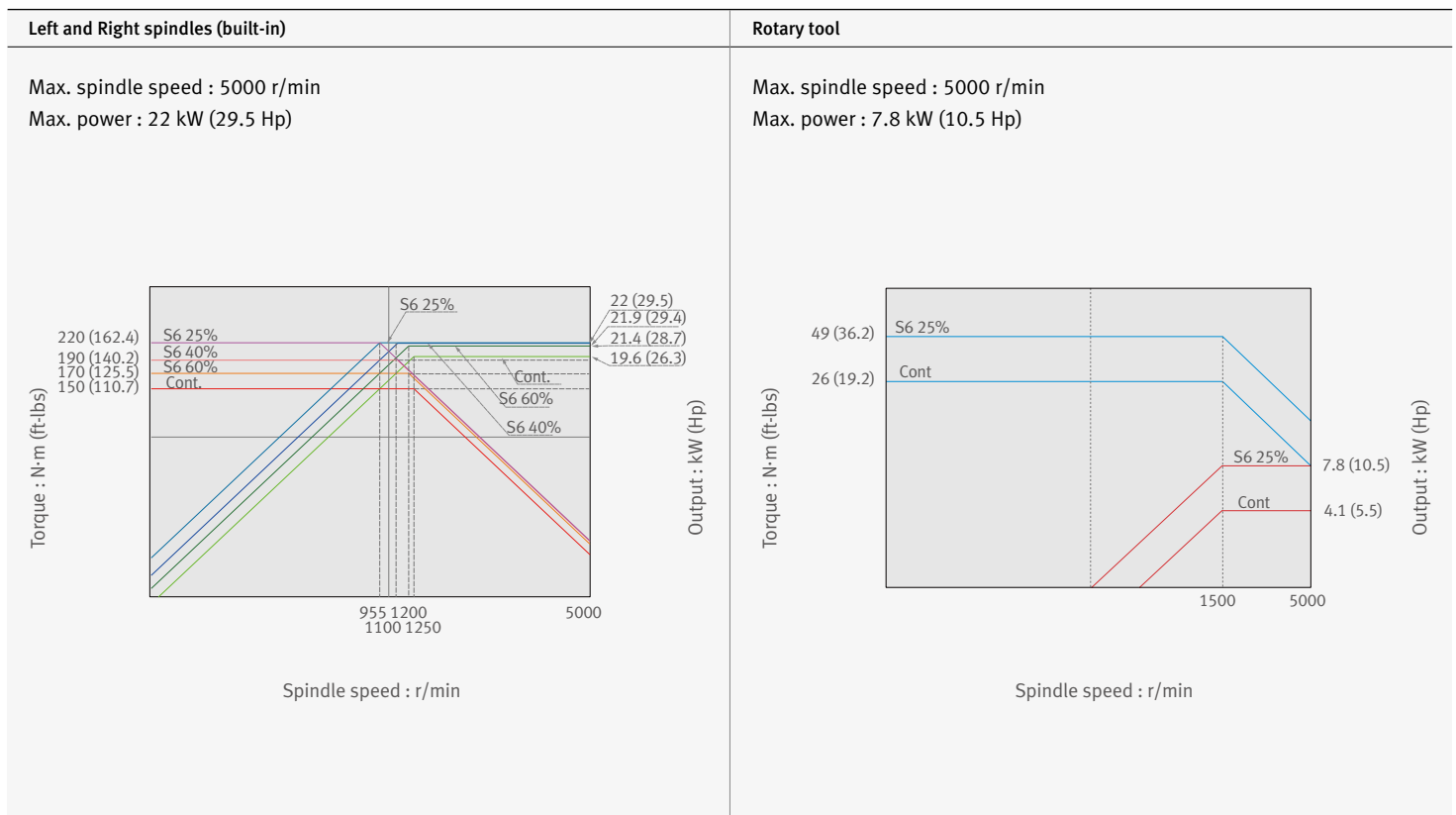

## External Dimensions

### Basic Information

Basic Structure  
Line-up /  
Processing

### Detailed Information

Options  
Applications  
Capacity Diagram  
Specifications

### Customer Support Service

## PUMA TT1800S / MS / SY

Unit : mm (inch)

Top View

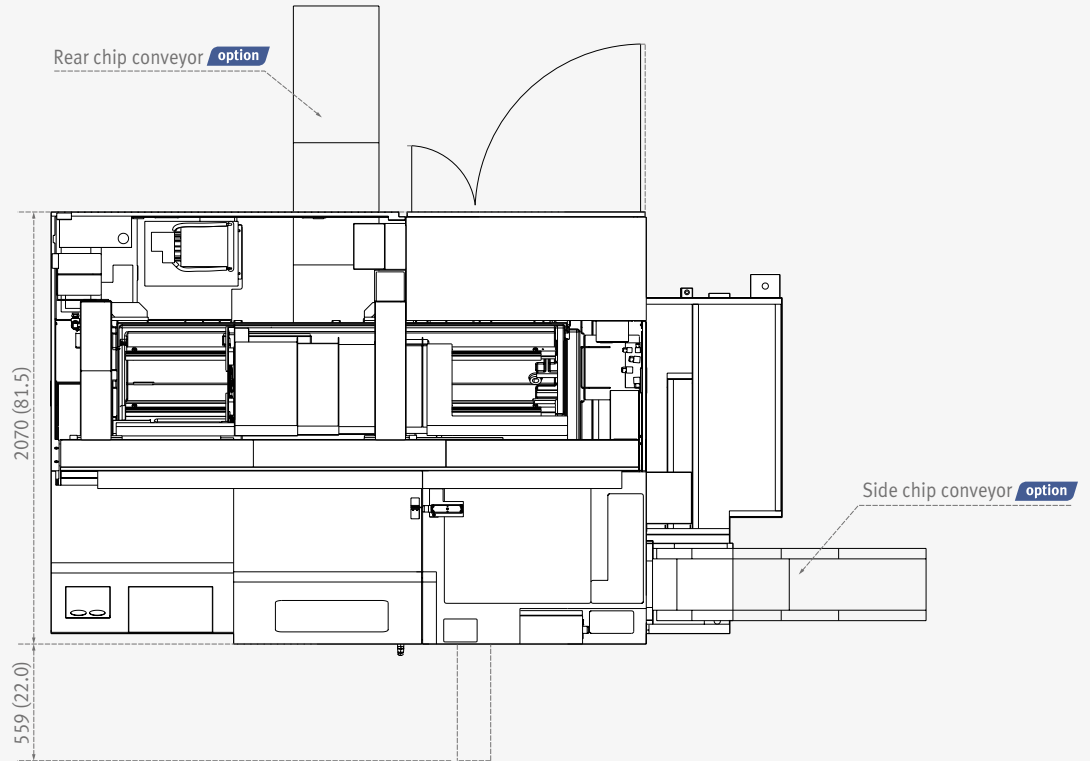

Front View

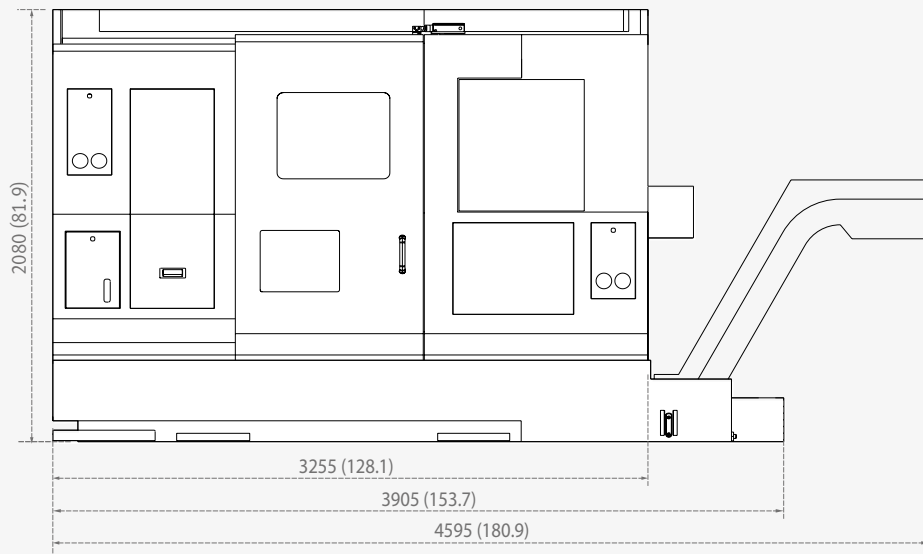

# Tooling System

## PUMA TT1800S / MS / SY

Unit : mm (inch)

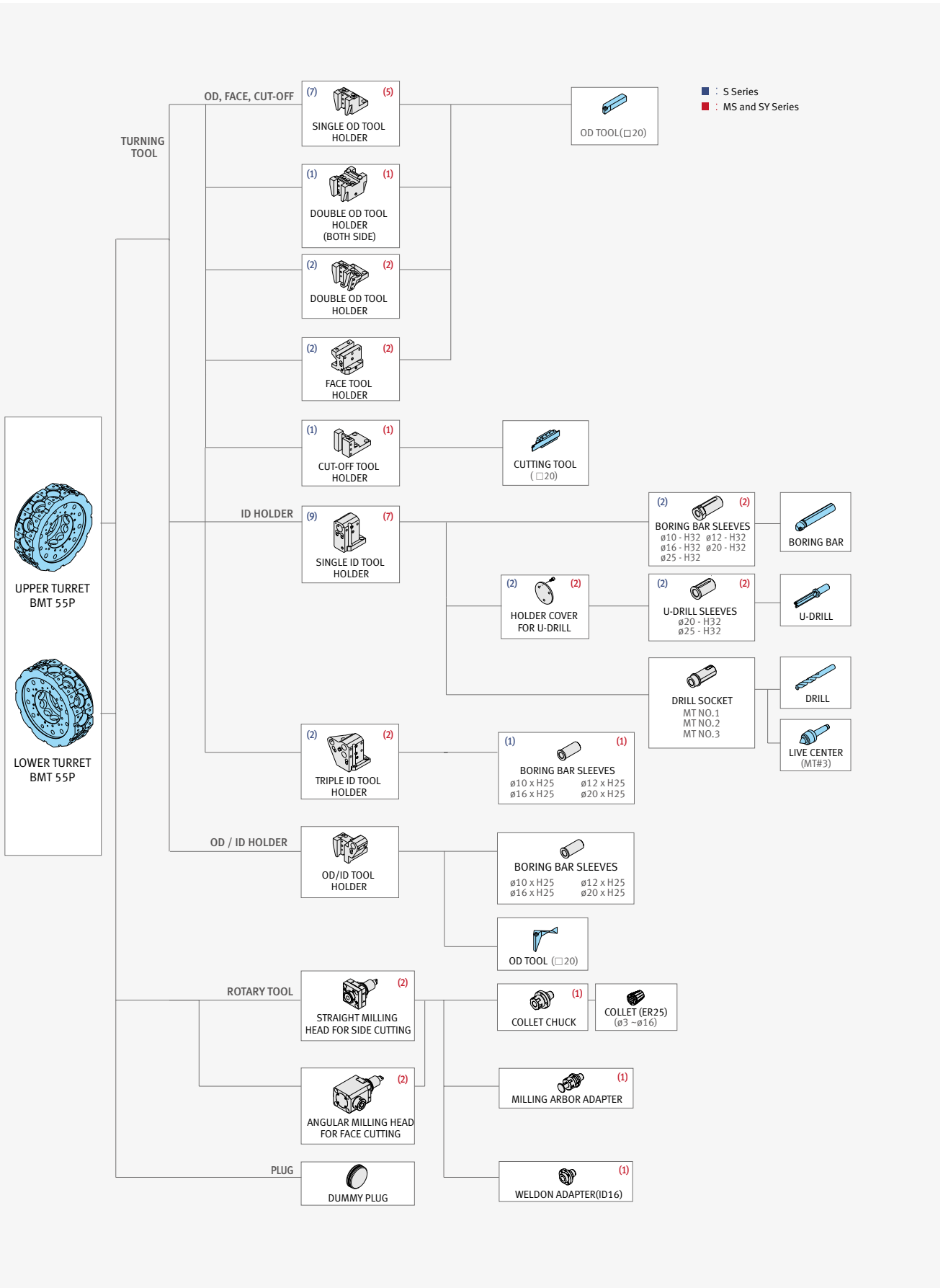

# Tool Interference Diagram

## Basic Information

# PUMA TT1800S / MS / SY

Unit : mm (inch)

Basic Structure  
Line-up /  
Processing

## Detailed Information

Options  
Applications  
Capacity Diagram  
Specifications

## Customer Support Service

Upper turret

Lower turret

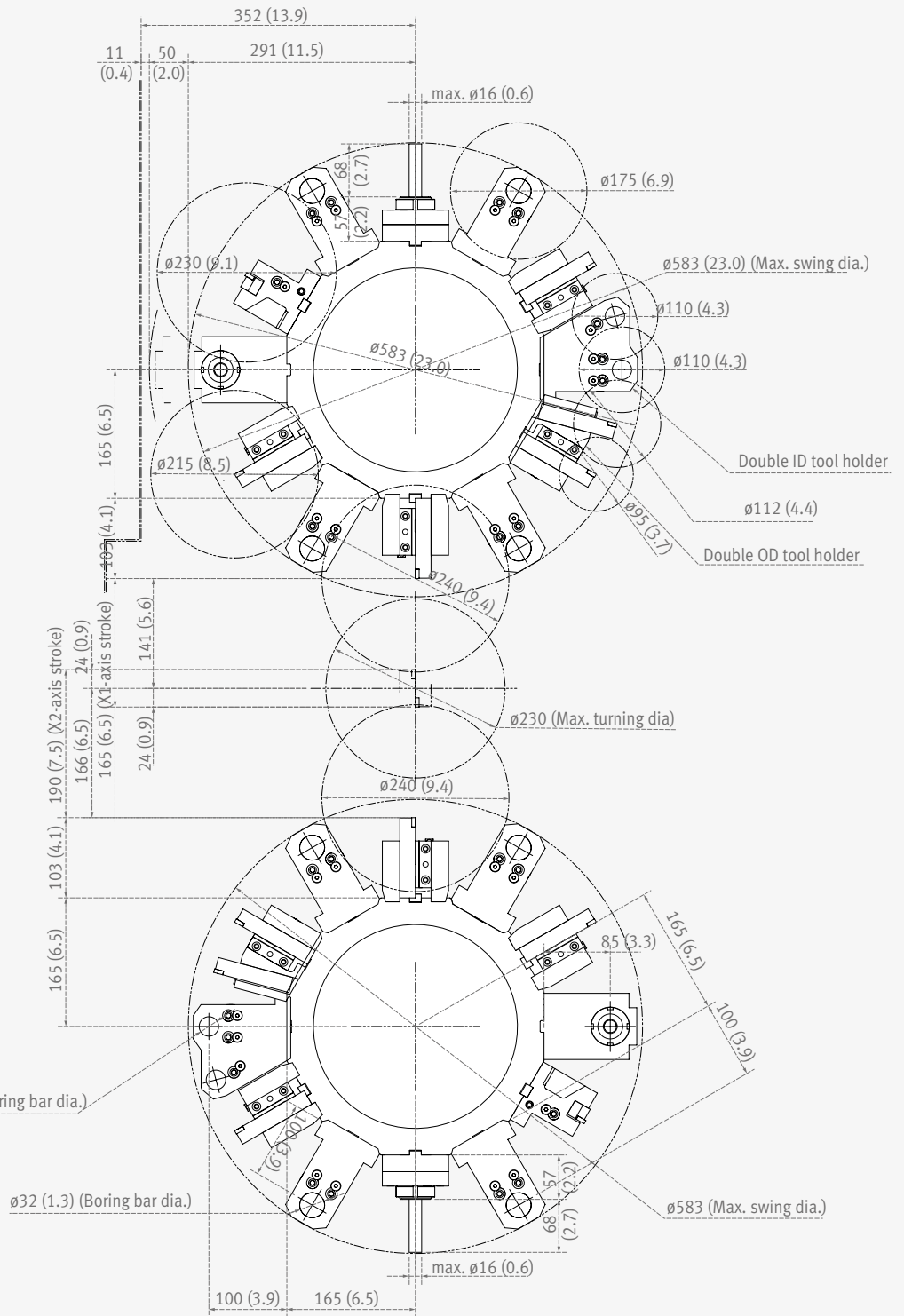

# Working Range Diagram

## PUMA TT1800S / MS / SY

Unit : mm (inch)

Single OD Tool holder

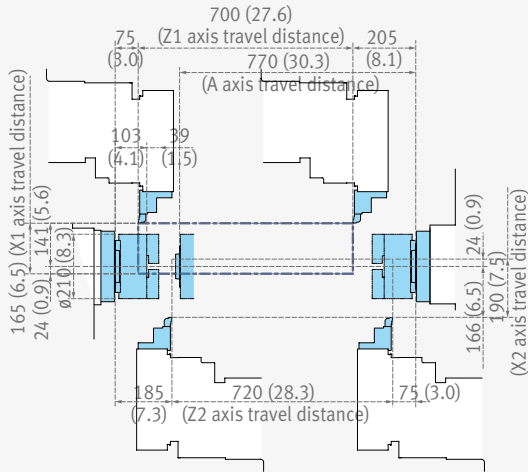

Double OD Tool holder

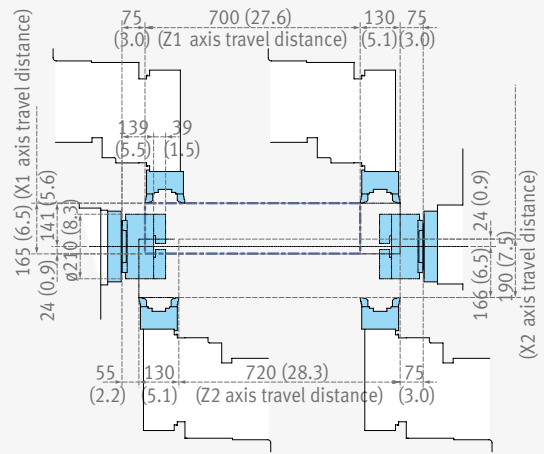

ID Tool holder

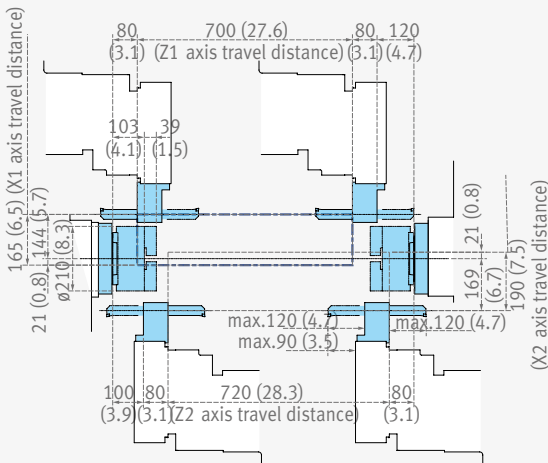

Angular milling head

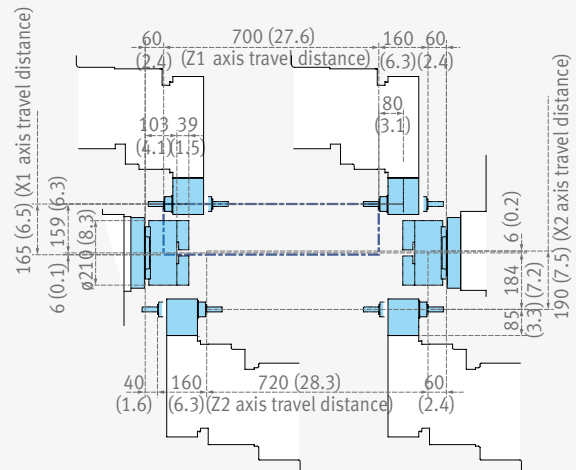

Straight milling head

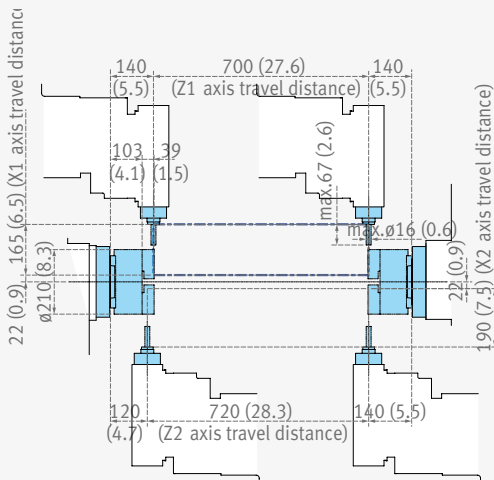

Y axis travel distance

Straight milling head

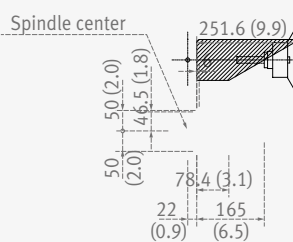

Angular milling head

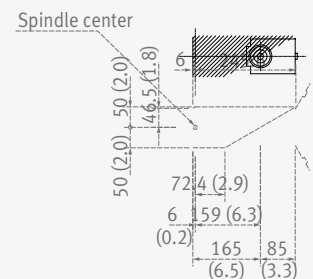

## Machine Specifications

## Basic Information

Basic Structure  
Line-up /  
Processing



## Detailed Information

Options  
Applications  
Capacity Diagram  
Specifications

## Customer Support Service

Description		Unit	PUMA TT1800S	PUMA TT1800MS	PUMA TT1800SY	
Capacity	Swing over bed	mm (inch)	230 (9.1)			
	Swing over saddle	mm (inch)	230 (9.1)			
	Recommended turning diameter	mm (inch)	210 (8.3)			
	Max. turning diameter	mm (inch)	Upper turret: 230 (9.1) / Lower turret: 230 (9.1)			
	Max. turning length	mm (inch)	230 (9.1)			
	Chuck size	inch	8			
	Bar working diameter	mm (inch)	65 (2.6)			
Feedrate	Travel distance	X1 / 2 axes	mm (inch)	X1: 165 (6.5) / X2: 190 (7.5)		
		Z1 / 2 axes	mm (inch)	Z1: 700 (27.6) / Z2: 720 (28.3)		
		Y-axis	mm (inch)	-	-	100 (3.9)
		A-axis	mm (inch)	770 (30.3)		
	Rapid traverse	X1 / 2 axes	m/min (ipm)	20 (787.4)		
		Z1 / 2 axes	m/min (ipm)	40 (1574.8)		
		Y-axis	m/min (ipm)	-	-	7.5 (295.3)
		A-axis	m/min (ipm)	40 (1574.8)		
Left spindle / Right spindle	Spindle speed	r/min	5000			
	Spindle motor power (FANUC) (30 min / cont.)	kW (Hp)	22 / 15 (29.5 / 20.1)			
	Spindle motor power (SIEMENS) (S6 40% / cont.)	kW(Hp)	22/19.6 (29.5/26.3)			
	Max. spindle torque (FANUC)	N·m (ft·lbs)	208 (153.5)			
	Max. spindle torque (SIEMENS)	N.m (ft-ibs)	220 (162.4)			
	Spindle nose	ASA	A2#6			
	Spindle bearing diameter	mm (inch)	110 (4.3)			
	Spindle inner diameter	mm (inch)	76 (3.0)			
C-axis min. indexing angle	deg	360 (in 0.001deg.increment)				
Turret	No. of tool stations (Upper + Lower)	ea	24 + 24			
	OD tool size	mm (inch)	20 x 20 (0.8 x 0.8)			
	Max. ID tool size	mm (inch)	32 (1.3)			
	Turret Indexing time	sec	0.15			
	Max. rotary tool speed	r/min	-	5000		
	Rotary tool motor power (FANUC) (S3 25%/cont.)	kW (Hp)	5.5 / 1.1 (7.4 / 1.5)			
	Rotary tool motor power (SIEMENS) (S6 25% /cont.)	kW (HP)	7.8/4.1 (10.5/5.5)			
Power Source	Power consumption	kVA	75.21			
Machine dimensions	Length	mm (inch)	3905 (153.7)			
	Width	mm (inch)	2070 (81.5)			
	Height	mm (inch)	2080 (81.9)			
	Weight	kg (lb)	8350 (18408.3)	8600 (18959.5)	8800 (19400.4)	
Control	NC system		FANUC 31i / SIEMENS 840D			

# NC Unit Specifications

● Standard ○ Optional X Not applicable

## FANUC 31i

NO.	Division	Item	Spec.	Fanuc 31i		
				S	MS	SY
1	Control axes	Control paths		2 Path	2 Path	2 Path
2		Controlled axes		5 (X1, Z1, X2, Z2, A)	7 (X1, Z1, C1, X2, Z2, C2, A)	8 (X1, Z1, C1, Y, X2, Z2, C2, A)
3		Simultaneously controlled axes		4 axes	4 axes	4 axes
4		Axis control by PMC		●	●	●
5		Cs contouring control		X	●	●
6		Synchronous/Composite control		●	●	●
7		Torque control		●	●	●
8		Increment system	ISA, IS-B	●	●	●
9		HRV2 control		●	●	●
10		Inch / metric conversion		●	●	●
11		Stored limit check before move		○	○	○
12		Chamfering on / off		●	●	●
13		Interference check for rotary area		●	●	●
14		Unexpected disturbance torque detection function		●	●	●
15		Position switch		●	●	●
16	Operation	Tool retract and recover		○	○	○
17		Dry run		●	●	●
18		Single block		●	●	●
19		Handle interruption		○	○	○
20		Incremental feed	x1, x10, x100	●	●	●
21		Manual handle retrace		○	○	○
22	Active block cancel		○	○	○	
23	Interpolation	Nano interpolation		●	●	●
24		Linear interpolation		●	●	●
25		Circular interpolation		●	●	●
26		Polar coordinate interpolation		●	●	●
27		Cylindrical interpolation		●	●	●
28		Helical interpolation		X	●	●
29		Thread cutting, synchronous cutting		●	●	●
30		Multi threading		●	●	●
31		Thread cutting retract		●	●	●
32		Continuous threading		●	●	●
33		Variable lead thread cutting		○	○	○
34		Circular thread cutting		○	○	○
35		Polygon machining with two spindles		●	●	●
36	High-speed skip	Input signal is 8 points.	○	○	○	
37	3rd/4th reference position return		○	○	○	
38	Balanced cutting	Only for more than 2 path control	●	●	●	
39	Feeding	Bell-shaped acceleration/deceleration after cutting feed interpolation		●	●	●
40		Override cancel		●	●	●
41		AI contour control I		●	●	●
42		AI contour control II		○	○	○
43	Rapid traverse block overlap		●	●	●	
44	Programming	Optional block skip	9 pieces	●	●	●
45		Absolute / incremental programming	Combined use in the same block	●	●	●
46		Diameter / Radius programming		●	●	●
47		Automatic coordinate system setting		●	●	●
48		Workpiece coordinate system	G52 - G59	●	●	●
49		Workpiece coordinate system preset		○	○	○
50		Addition of workpiece coordinate system	48 pairs	○	○	○
51		Addition of workpiece coordinate system	300 pairs	○	○	○
52		Direct drawing dimension programming		●	●	●
53		Chamfering / Corner R		○	○	○
54		Custom macro		●	●	●
55		Addition of custom macro common variables	#100 - #199, #500 - #999	●	●	●

## Basic Information

Basic Structure  
Line-up /  
Processing

Detailed  
Information

Options  
Applications  
Capacity Diagram  
Specifications

Customer Support  
Service

# FANUC 31i

NO.	Division	Item	Spec.	Fanuc 31i			
				S	MS	SY	
56	Programming	Custom macro common variables between each path	Only for more than 2 path control. Included in Custom macro.	●	●	●	
57		Interruption type custom macro		○	○	○	
58		Canned cycle		●	●	●	
59		Multiple repetitive cycles	G70~G76	●	●	●	
60		Multiple repetitive cycles II	Pocket profile	●	●	●	
61		Canned cycle for drilling		●	●	●	
62		Automatic corner override		○	○	○	
63		Custom software (Total amount of each path)	12MByte	●	●	●	
64		Coordinate system shift		●	●	●	
65		Direct input of coordinate system shift		●	●	●	
66		Real time custom macro		○	○	○	
67		Pattern data input		○	○	○	
68		Interactive programming	EZ Guidei (Conversational Programming Solution)		●	●	●
69			Easy Operation Package		●	●	●
70	Auxiliary / spindle function	High-speed M / S / T / B interface		●	●	●	
71		Waiting M codes of high-speed type	Only for more than 2 path control	●	●	●	
72		Constant surface speed control		●	●	●	
73		Spindle override	0 - 150%	●	●	●	
74		Spindle orientation		●	●	●	
75		Spindle synchronous control		●	●	●	
76		Rigid tap		●	●	●	
77		Arbitrary speed threading		○	○	○	
78	Tool function / tool compensation	Tool offset pairs	99-pairs	●	●	●	
79			128 / 200 / 400 / 499 / 999 pair	○	○	○	
80		Common offset memory between each path	Only for more than 2 path control	●	●	●	
81		Tool offset		●	●	●	
82		Tool radius/Tool nose radius compensation		●	●	●	
83		Tool geometry/wear compensation		●	●	●	
84		Automatic tool offset		●	●	●	
85		Direct input of offset value measured B		●	●	●	
86	Tool life management		●	●	●		
87	Tool function / tool compensation	Backlash compensation for each rapid traverse and cutting feed		●	●	●	
88		Stored pitch error compensation		●	●	●	
89	Editing	Part program storage size & Number of registerable programs	640M (256KB)_500 programs	○	○	○	
90			1280M (512KB)_1000 programs	●	●	●	
91			1MB / 2MB / 4MB / 8MB 1000 / 2000 / 4000 programs	○	○	○	
92		Program protect		●	●	●	
93	Password function		●	●	●		
94	Playback		○	○	○		
95	Memory card program edit & operation	Max 63 programs	●	●	●		
96	Data input / output	Fast data server		○	○	○	
97		External data input		●	●	●	
98		Memory card input / output		●	●	●	
99		USB memory input / output		●	●	●	
100		Automatic data backup		●	●	●	
101	Interfacing	Embedded Ethernet		●	●	●	
102		Fast Ethernet		○	○	○	
103	Other functions	Display unit	10.4" color LCD	●	●	●	
104	Robot interface	Robot interface with PMC I/O module		○	○	○	
105		Robot interface with PROFIBUS-DP		○	○	○	



# NC Unit Specifications

● Standard ○ Optional ✕ Not applicable



NO.	Division	Item	Spec.	S 840D
				PUMA TT series
1	Control axes	Simultaneously controlled axes	Positioning (G00) / Linear interpolation (G01) : 3 axes Circular interpolation (G02, G03) : 2 axes	●
2		Backlash compensation		●
3		Leadscrew error compensation		●
4		Measuring system error compensation		●
5		Feedforward control	velocity-dependent	●
6		Follow up mode		●
7		Programmable acceleration		●
8		Least command increment	0.001mm (0.0001 inch)	●
9		Least input increment	0.001mm (0.0001 inch)	●
10	INTERPOLATION & FEED FUNCTION	2nd reference point return	G75 FP=2	●
11		3rd / 4th reference return	G75 FP=3, 4	●
12		Linear interpolation	Max. 4	●
13		Circular interpolation	G02, G03	●
14		Helical interpolation		●
15		Universal interpolator NURBS		●
16		Polynomial interpolation		○
17		Spline interpolation (A, B and C splines)		●
18		Involute interpolation		○
19	Separate path feed for corners and chamfers		●	
20	SPINDLE FUNCTION	Retraction for rigid tapping		●
21		Rigid tapping		●
22	TOOL FUNCTION	3D Tool radius compensation		○
23		Number of tools / cutting edges in tool list		600 / 1500
24		Tool length compensation		●
25		Replacement tools for tool management		○
26		Monitoring of tool life and workpiece count		●
27		Manual measurement of tool offset		●
28		Loading and unloading of tools		●
29	PROGRAMMING & EDITING FUNCTION	Number of subroutine passes ≤ 9999		●
30		Polar coordinates		●
31		Dimensions metric/inch, changeover manually or via program		●
32		Dynamic preprocessing memory FIFO		●
33		Look ahead number of blocks		150
34		Geometry axes, switchable online in the CNC program		●
35		Parts programs on NCU, max. number		1000
36		Workpieces on NCU, max. number		250
37		ShopTurn / ShopMill Machining step programming		●
38		Technology cycles for drilling/milling		●
39		Pocket milling free contour and islands stock removal cycle		●
40		2D simulation		●
41		3D simulation, finished part		●
42		Simultaneous recording		●
43		OTHERS FUNCTIONS (Operation, setting & Display, etc)	Execution from USB or CF card interface on operator panel front	
44	Execution from HMI memory on NCU CF card			●
45	19.0" color display			●
46	Multi-channel display			●
47	2D representation of 3D protection areas / work areas			●
48	Software and hardware limit switches			●
49	Position monitoring			●
50	2D / 3D protection zones			●
51	Contour monitoring			●
52	Alarms and messages			●
53	RCS Commander (viewer function)			●
54	Automatic measuring cycles			●
56	Contour handwheel			○
57	Integrate screens in SINUMERIK Operate with SINUMERIK Integrate Run MyScreens			●
58	MDynamics 3-axis			●

# Responding to Customers Anytime, Anywhere

Basic Information

Basic Structure  
Line-up /  
Processing

Detailed  
Information

Options  
Applications  
Capacity Diagram  
Specifications

Customer Support  
Service



## Global Service Support Network

Corporations

5

Dealer Networks

122

Technical Centers

18

Factories

3

Technical Center: Sales Support, Service Support, Parts Support

**Doosan Machine Tools' Global Network, Responding to Customer's Needs nearby, Anytime, Anywhere**

Doosan machine tools provides a system-based professional support service before and after the machine tool sale by responding quickly and efficiently to customers' demands. By supplying spare parts, product training, field service and technical support, we can provide top class support to our customers around the world.

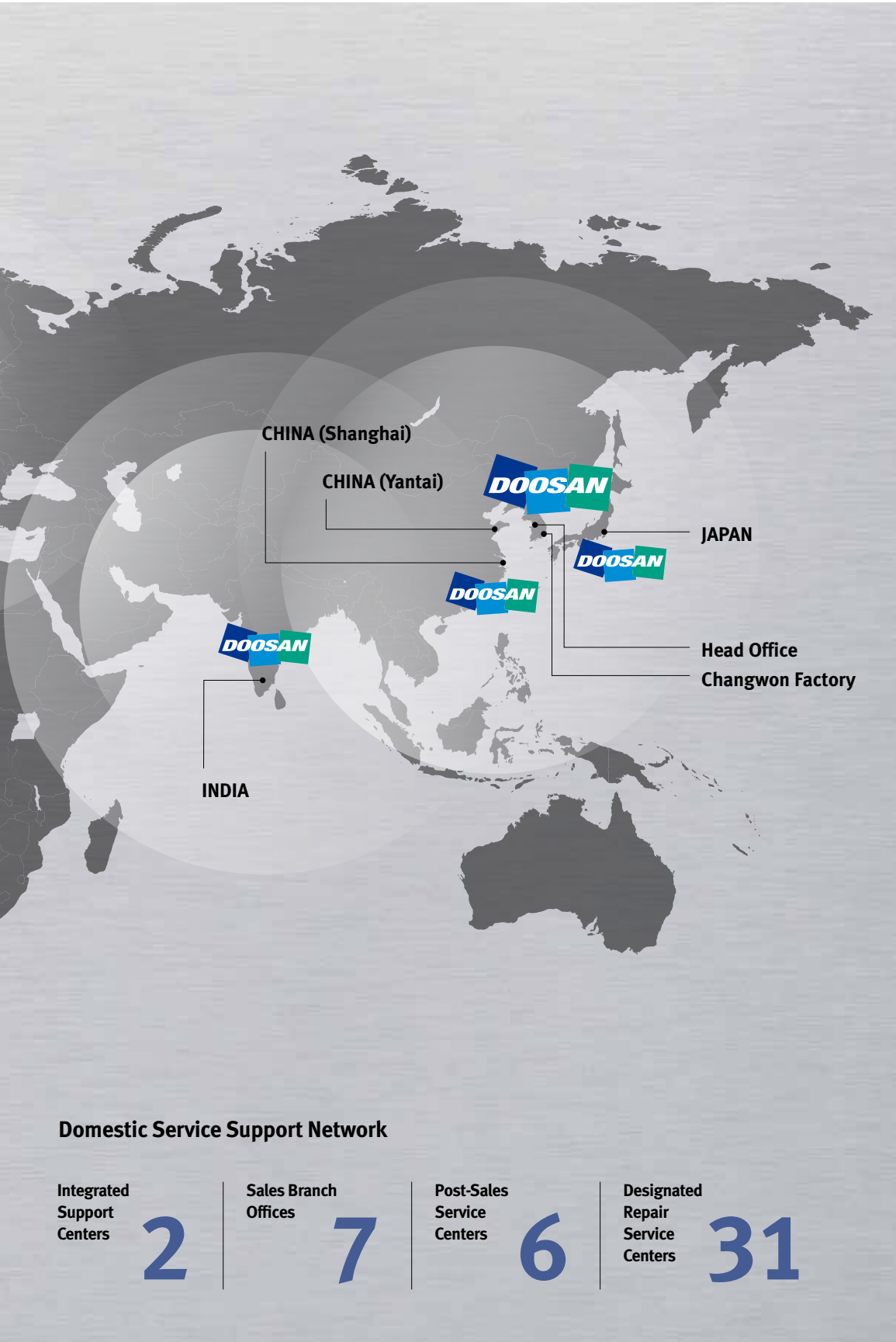

**Customer Support Service**

We help customers to achieve success by providing a variety of professional services from pre-sales consultancy to post-sales support.

**Supplying Parts**



- Supplying a wide range of original Doosan spare parts
- Parts repair service

**Field Services**



- On site service
- Machine installation and testing
- Scheduled preventive maintenance
- Machine repair

**Technical Support**



- Supports machining methods and technology
- Responds to technical queries
- Provides technical consultancy

**Training**



- Programming / machine setup and operation
- Electrical and mechanical maintenance
- Applications engineering

## PUMA TT1800 series



Specification	UNIT	PUMA TT1800S / MS / SY
Max. turning diameter	mm (inch)	230 (9.1)
Max. turning length	mm (inch)	230 (9.1)
Chuck size	inch	8
Bar working diameter	mm (inch)	65 (2.6)
Spindle speed (Left spindle / Right spindle)	r/min	5000
Spindle motor power (Left spindle / Right spindle)	kW (Hp)	22 / 15 (30 min / cont.) (29.5 / 20.1) (FANUC) 22/19.6 (S6 40% / cont.) (29.5 / 26.3) (SIEMENS)
NC system	-	FANUC 31i / SIEMENS 840D



## Doosan Machine Tools

<http://www.doosanmachinetools.com>

[www.facebook.com/doosanmachinetools](https://www.facebook.com/doosanmachinetools)

### Optimal Solutions for the Future

#### Head Office

Yeonkang Bldg., 6th FL., 270, Yeonji-dong,  
Jongno-gu, Seoul, Korea  
Tel +82-2-3670-5345 / 5362  
Fax +82-2-3670-5382

#### Doosan Machine Tools China

Room 101,201,301, Building 39 Xinzhuan Highway  
No.258 Songjiang District,China Shanghai(201612)  
Tel +86 21-5445-1155  
Fax +86 21-6405-1472

#### Doosan Machine Tools Japan

#2412, Mita Kokusai Bldg. 1-4-28 Mita,  
Minato-ku, Tokyo 108-0073, Japan  
Tel +81 3 5730 9013  
Fax +81 3 5730 9016

#### Doosan Machine Tools America

19A Chapin Rd., Pine Brook, NJ 07058, U.S.A.  
Tel +1-973-618-2500  
Fax +1-973-618-2501

#### Doosan Machine Tools Europe

Emdener Strasse 24, D-41540 Dormagen, Germany  
Tel +49-2133-5067-100  
Fax +49-2133-5067-111

#### Doosan Machine Tools India

106 / 10-11-12, Amruthahalli, Byatarayanapura,  
Bellary road, Bangalore-560 092, India  
Tel +91-80-4266-0122 / 121 / 100



\* For more details, please contact Doosan Machine Tools.

\* The specifications and information above-mentioned may be changed without prior notice.

\* Doosan Machine Tools Co., Ltd. is a subsidiary of MBK Partners. The trademark  DOOSAN is used under a licensing agreement with Doosan Corporation, the registered trademark holder.